



# ZERO EDGE PRO



## Owner's Manual



**INSTALLERS:** PLEASE BE SURE TO LEAVE THIS  
MANUAL WITH THE OWNER. THANK YOU!

APPLY S/N  
STICKER HERE



## LIMITED ONE YEAR WARRANTY ON SCREEN INNOVATIONS PRODUCTS

Screen Innovations warrants its products, to the original purchaser only, to be free from defects in materials and workmanship for a period of one (1) year from the date of purchase by the original purchaser provided they are properly operated according to Screen Innovations' instructions and are not damaged due to improper handling or treatment after shipment from the factory.

This warranty does not apply to equipment showing evidence of misuse, abuse, or accidental damage, or which has been tampered with or repaired by a person other than authorized Screen Innovations personnel.

Screen Innovations' sole obligation under this warranty shall be to repair or to replace (at Screen Innovations' option) the defective part of the merchandise. Returns for service should be made to your Screen Innovations' dealer. If it is necessary for the dealer to return the screen or part to Screen Innovations, transportation expenses to and from Screen Innovations are payable by the purchaser and Screen Innovations is not responsible for damage in shipment. To protect yourself against damage or loss in transit, insure the product and prepay all transportation expenses.

**THIS WARRANTY IS IN LIEU OF ALL OTHER WARRANTIES, EXPRESS OR IMPLIED, INCLUDING WARRANTIES AS TO FITNESS FOR USE AND MERCHANT ABILITY. Any implied warranties of fitness for use, or merchantability, that may be mandated by statute or rule of law are limited to the one (1) year warranty period. This warranty gives you specific legal rights, and you may also have other rights, which vary from state-to-state. NO LIABILITY IS ASSUMED FOR EXPENSES OR DAMAGES RESULTING FROM INTERRUPTION IN OPERATION OF EQUIPMENT, OR FOR INCIDENTAL, DIRECT, OR CONSEQUENTIAL DAMAGES OF ANY NATURE.**

**In the event that there is a defect in materials or workmanship of a Screen Innovations product, you may contact our Sales Partners at 9715-B Burnet Road Suite 400, Austin, TX 78758, (512) 832-6939.**

**IMPORTANT: THIS WARRANTY SHALL NOT BE VALID AND SCREEN INNOVATIONS SHALL NOT BE BOUND BY THIS WARRANTY IF THE PRODUCT IS NOT OPERATED IN ACCORDANCE WITH SCREEN INNOVATIONS' WRITTEN INSTRUCTIONS.**

Keep your sales receipt to prove the date of purchase and your original ownership.

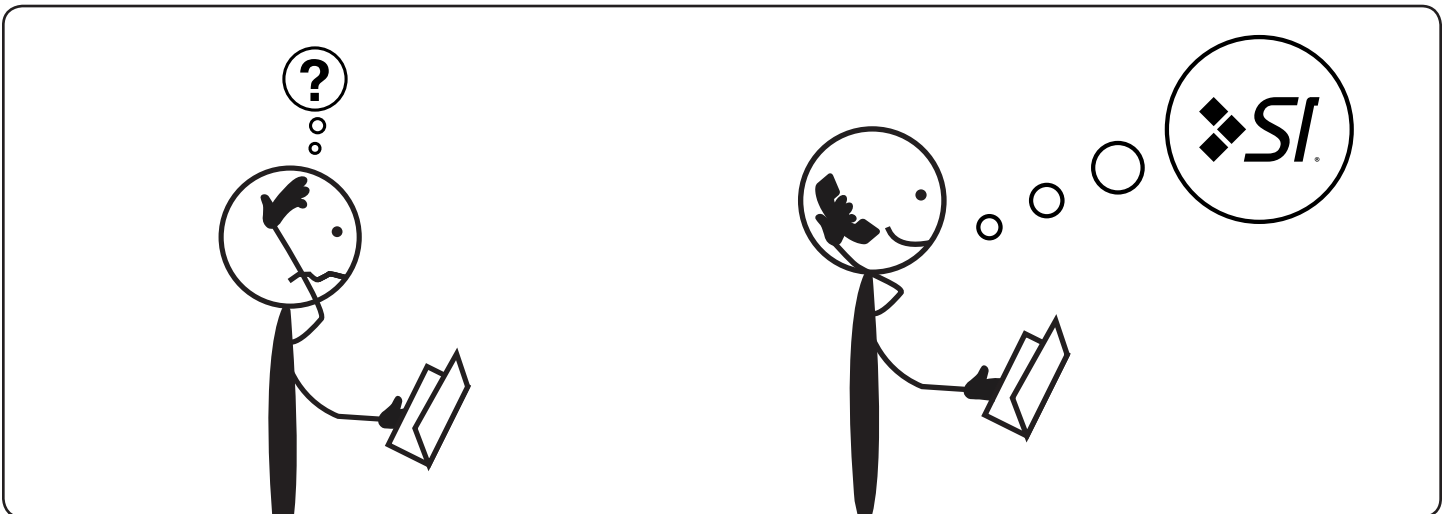
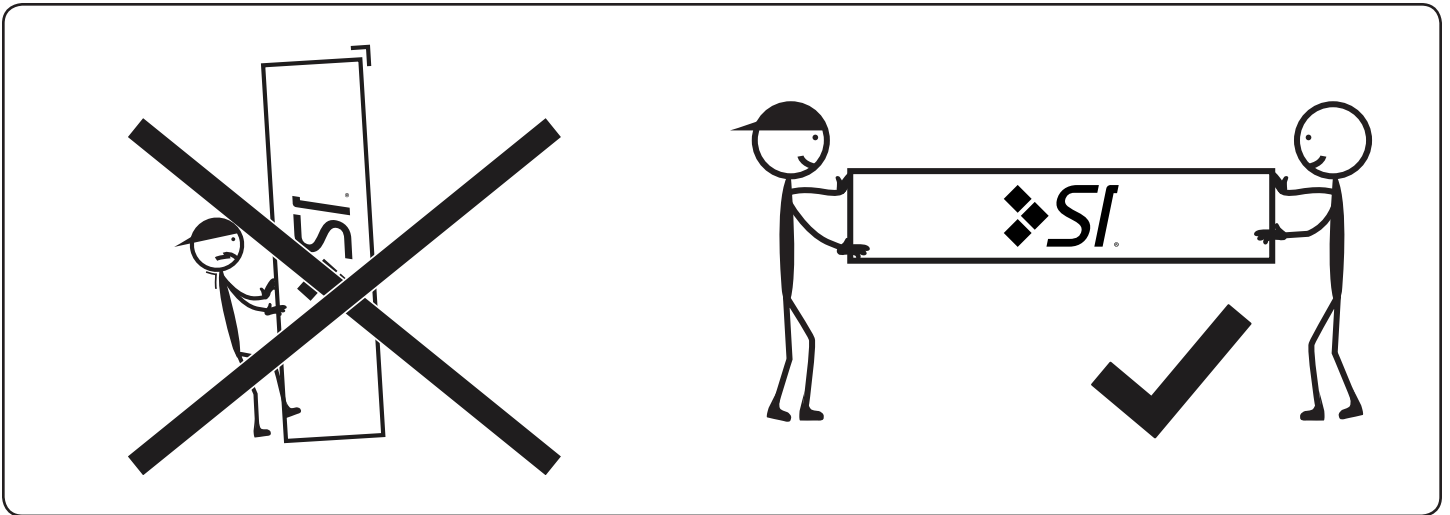

**512-832-6939**

9715-B Burnet Road Suite 400, Austin, TX 78758  
**SCREENINNOVATIONS.COM**

# Table of Contents

SUGGESTED PROJECTOR PLACEMENT .....	5
STANDARD FRAME PARTS LIST .....	7
STANDARD FRAME ASSEMBLY.....	9
SPLIT FRAME PARTS LIST .....	12
SPLIT FRAME ASSEMBLY.....	14
LED LIGHTS ATTACHMENT .....	18
BLACK DIAMOND OR SHORT THROW ATTACHMENT .....	21
SLATE OR PURE ATTACHMENT .....	25
BLACK BACKER ATTACHMENT .....	28
MAESTRO ATTACHMENT.....	29
BLACK BACKER ATTACHMENT .....	32
SMALL TRIM ATTACHMENT .....	34
MEDIUM OR LARGE TRIM ATTACHMENT.....	36
LOGO ATTACHMENT.....	38
TRIM REMOVAL .....	39
WALL INSTALLATION .....	41
FLOWN INSTALLATION.....	43
IR LIGHTING HEX CODES .....	45
IP CONTROLLED LIGHTING SETUP .....	46

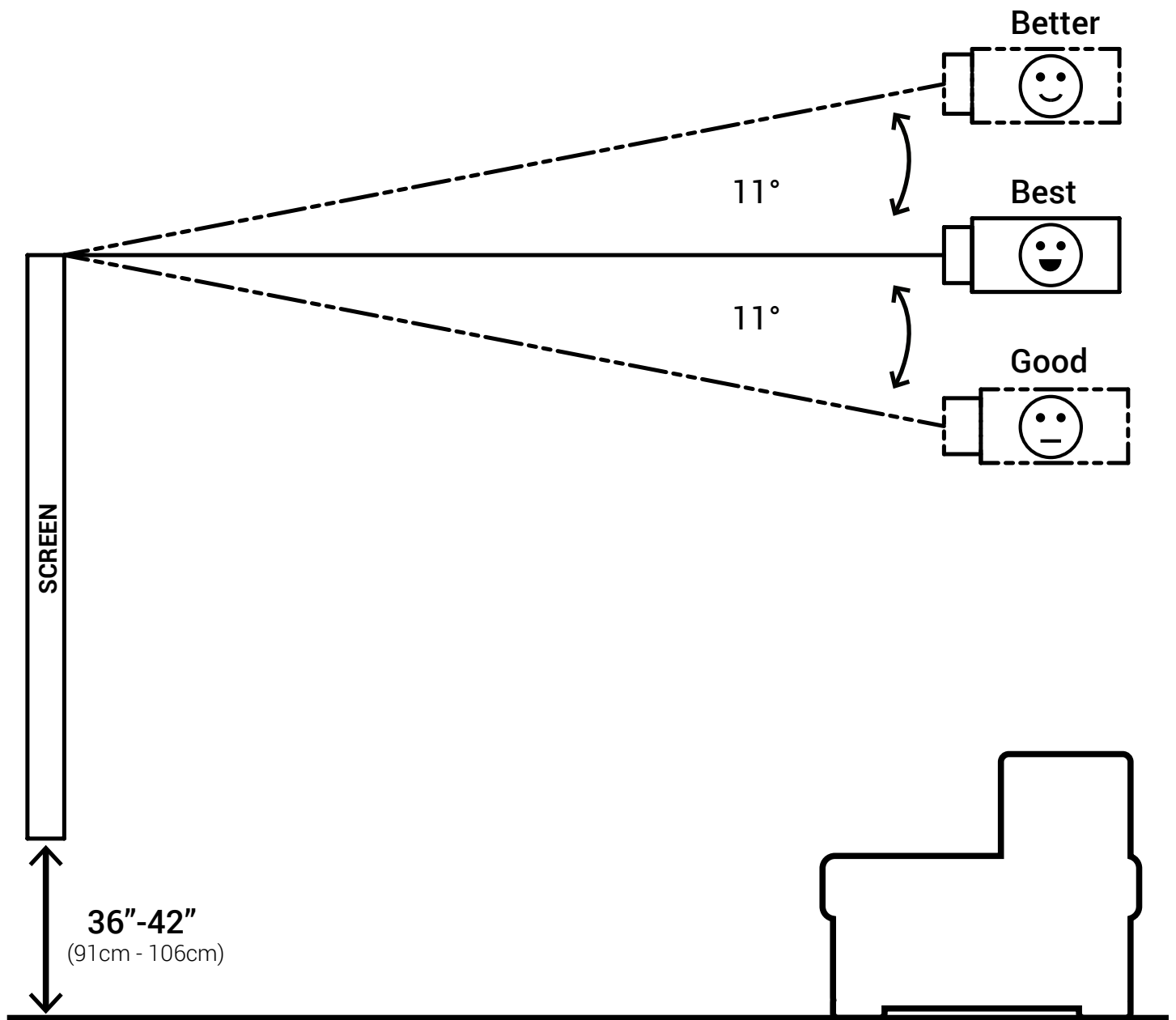

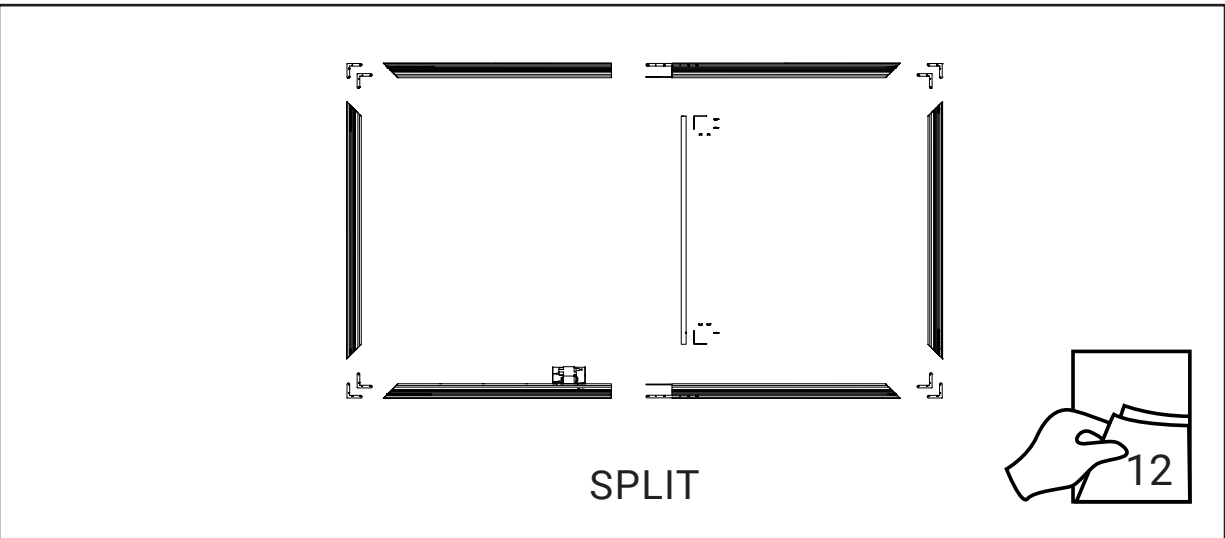
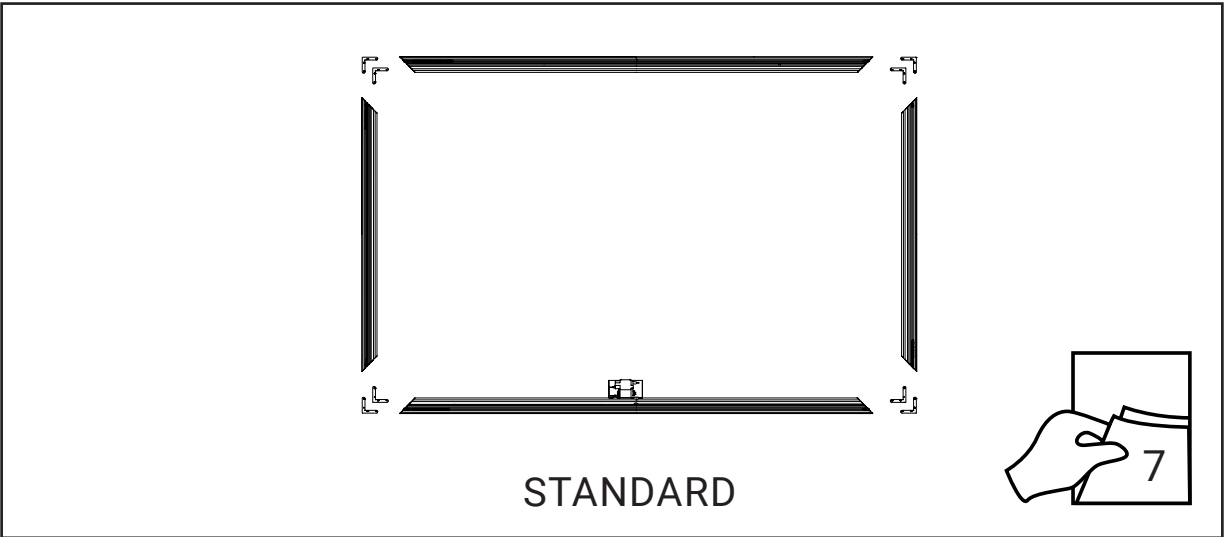
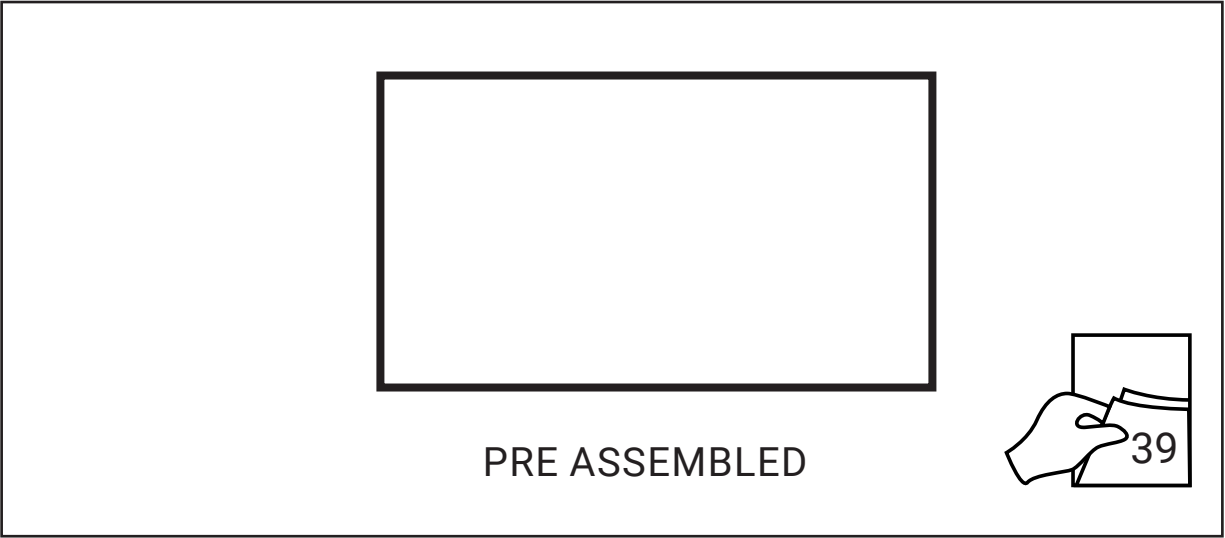

# STANDARD FRAME PARTS LIST

(LED Lights Only)

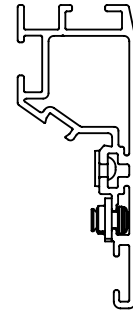
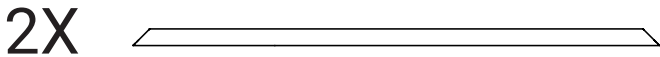
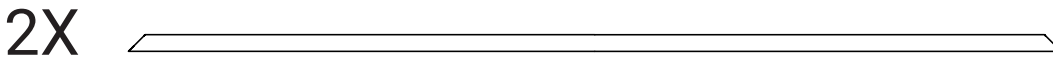
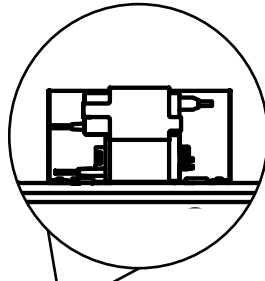
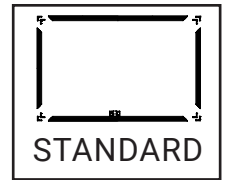

1/2" Small trim option

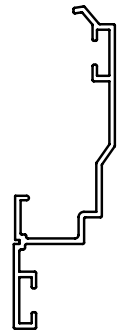

1 1/2" or 2" trim option

## Hardware Kit

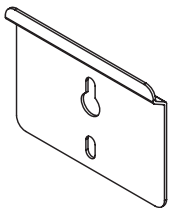

Wall Brackets

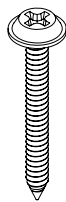

Mounting Screws

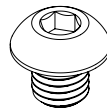

4X  
1/4-20 x 1/4" Screws  
(Small trim only)

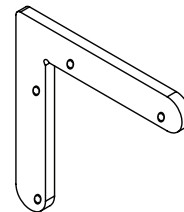

4X Thick Corner Brackets

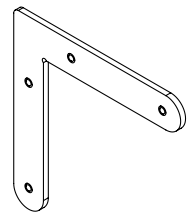

4X Thin Corner Brackets

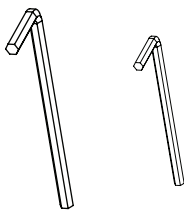

1/8" & 5/32" Hex Keys

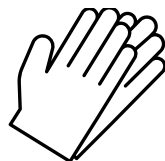

4X Gloves

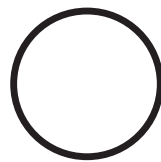

Bungees  
(Maestro only)

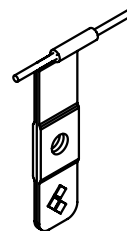

SI Attachment Bands  
(Black Diamond and Short Throw Only)

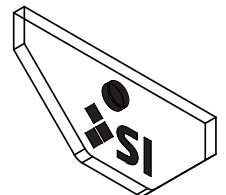

Acrylic Logo

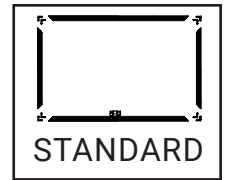

If IP controlled LED lights are ordered, Phillips Hue hub must be purchased and set up separately. See page 46 for IP lighting Instructions.

### LED IR Controlled Only



LED Remote

### Flying Mount Only

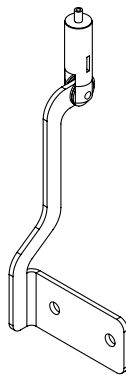

2X Flown Screen Mount

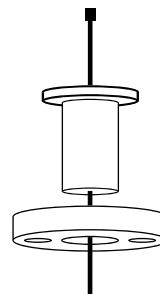

2X Flown Ceiling Mount

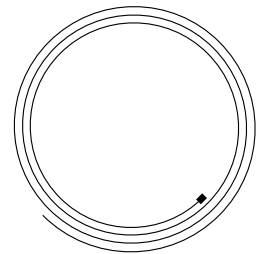

2X Flown Cable

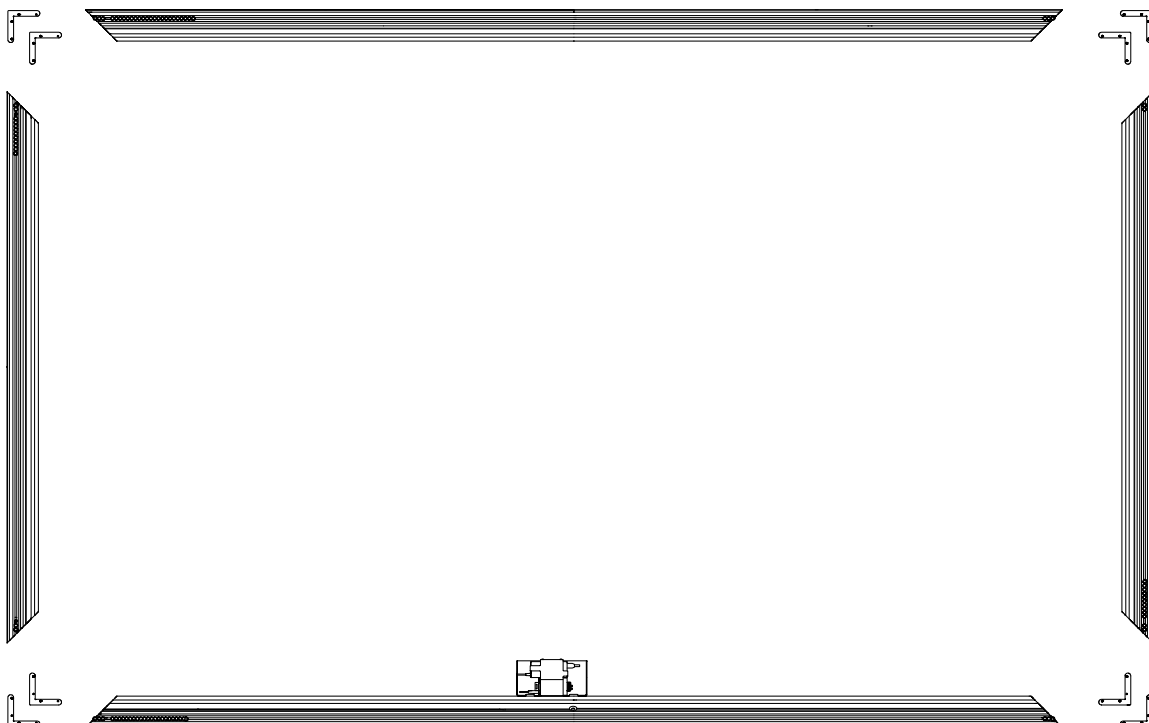



# STANDARD FRAME ASSEMBLY

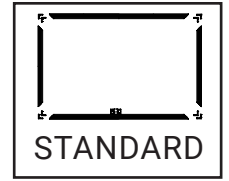

1

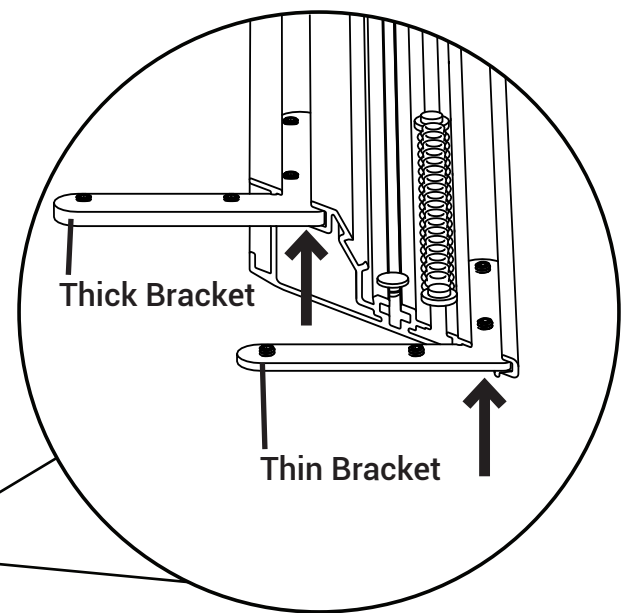
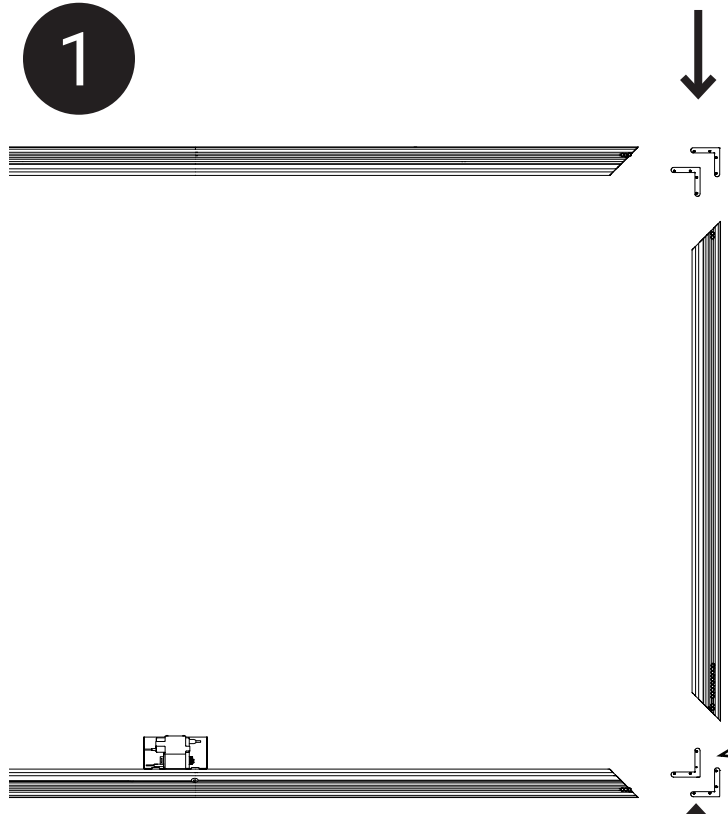

2

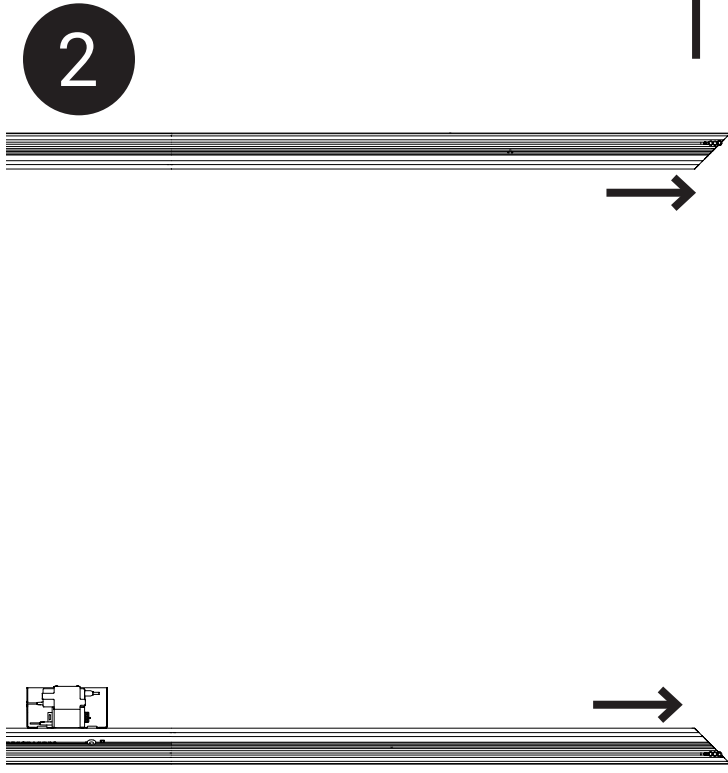

Insert the thin corner brackets into the outside channels and the thick corner brackets into the inside channels of the vertical frames. Then slide into the channels in the horizontal frames.

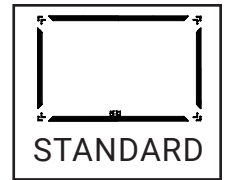

3

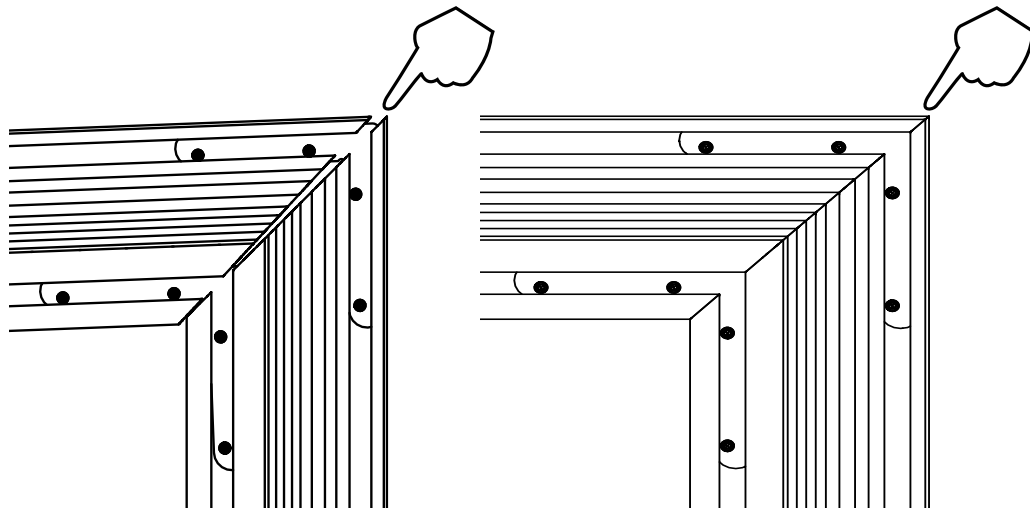

4

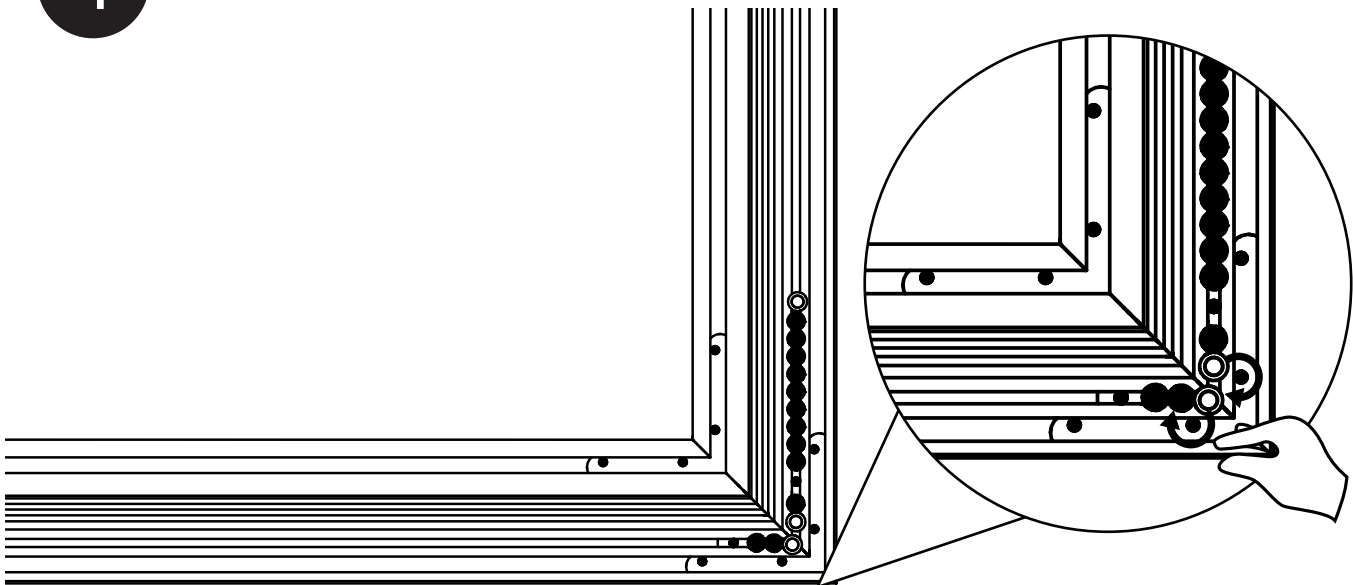

Make sure the points on the frame pieces line up. Then finger tighten 2 of the set screws to lock in the corners.

5

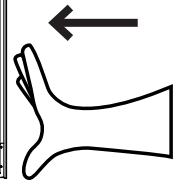
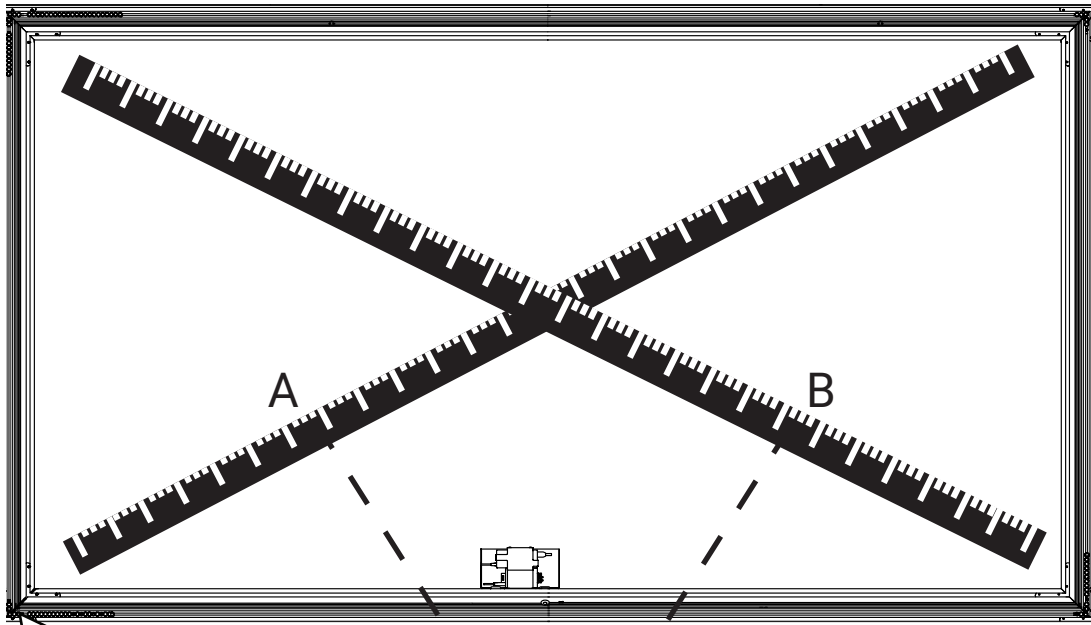
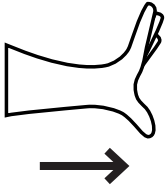
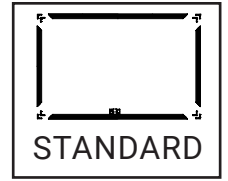
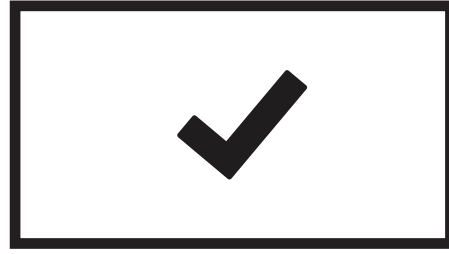
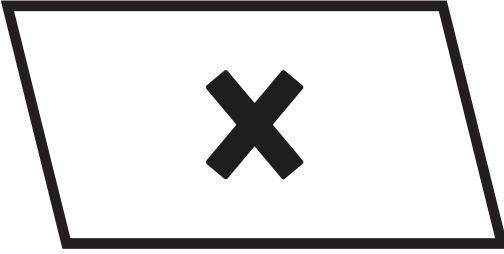

A = B

6

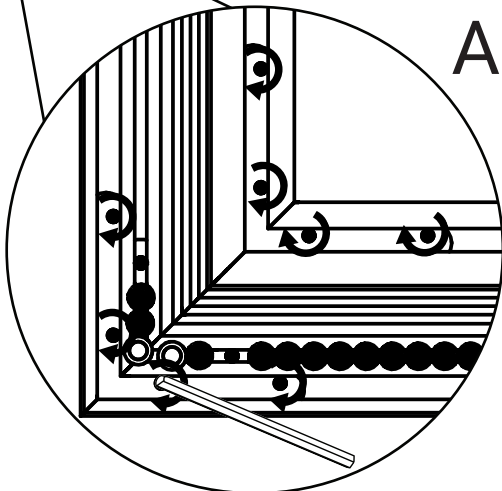

Measure the diagonals to check if frame is square. If one diagonal is longer then push on the corners at that diagonal. Tighten all set screws once the diagonals are equal to within 1/8".

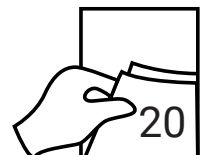
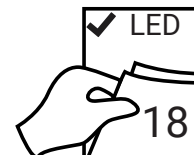

# SPLIT FRAME PARTS LIST

(LED Lights Only)

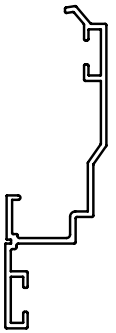
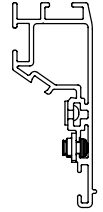
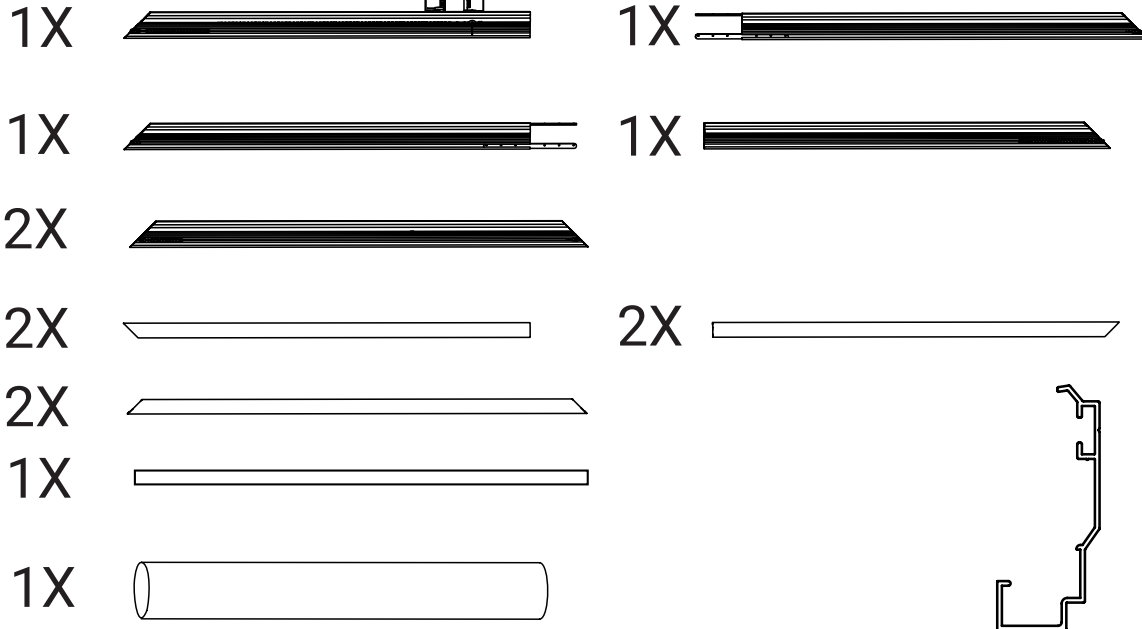
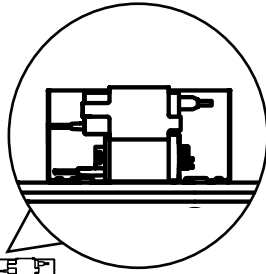
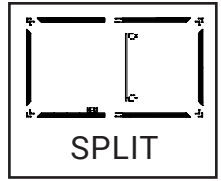

1/2" Small trim option

1 1/2" or 2" Trim option

## Hardware Kit

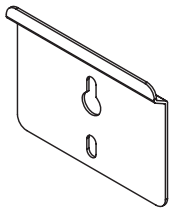

Wall Brackets

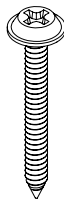

Mounting Screws

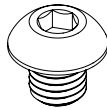

8X  
1/4-20 x 1/4"  
Screws  
(Small Trim Only)



4X  
1/4-20 Wing  
nuts



4X  
1/4-20 Thumb  
Screws

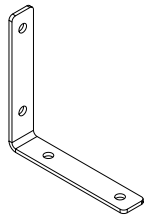

2X Vertical  
Support  
Brackets

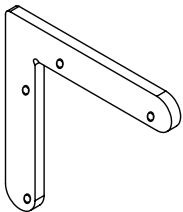

4X Thick Corner  
Brackets

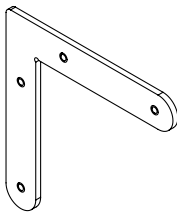

4X Thin Corner  
Brackets

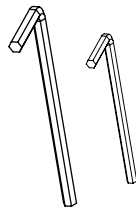

1/8" & 5/32" or  
3/32" Hex Keys

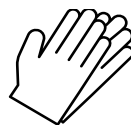

4X Gloves

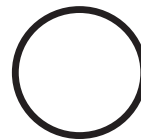

Bungees  
(Maestro only)

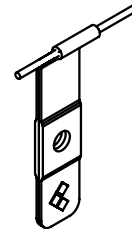

SI Attachment  
Bands  
(Black Diamond and  
Short Throw Only)

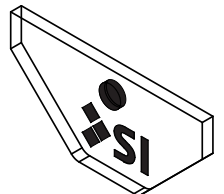

Acrylic Logo

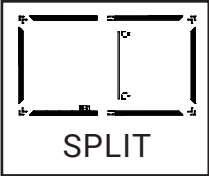

If IP controlled LED lights are ordered, Phillips Hue hub must be purchased and set up separately, see page 46 for IP lighting Instructions.

### LED IR Controlled Only

### Flying Mount Only



LED Remote

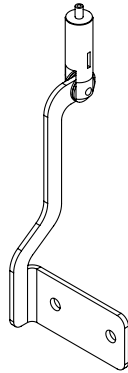

2X Flown Screen Mount

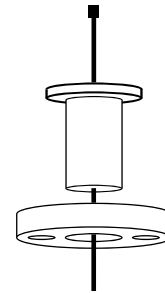

2X Flown Ceiling Mount

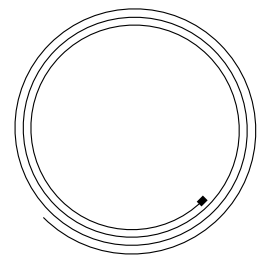

2X Flown Cable

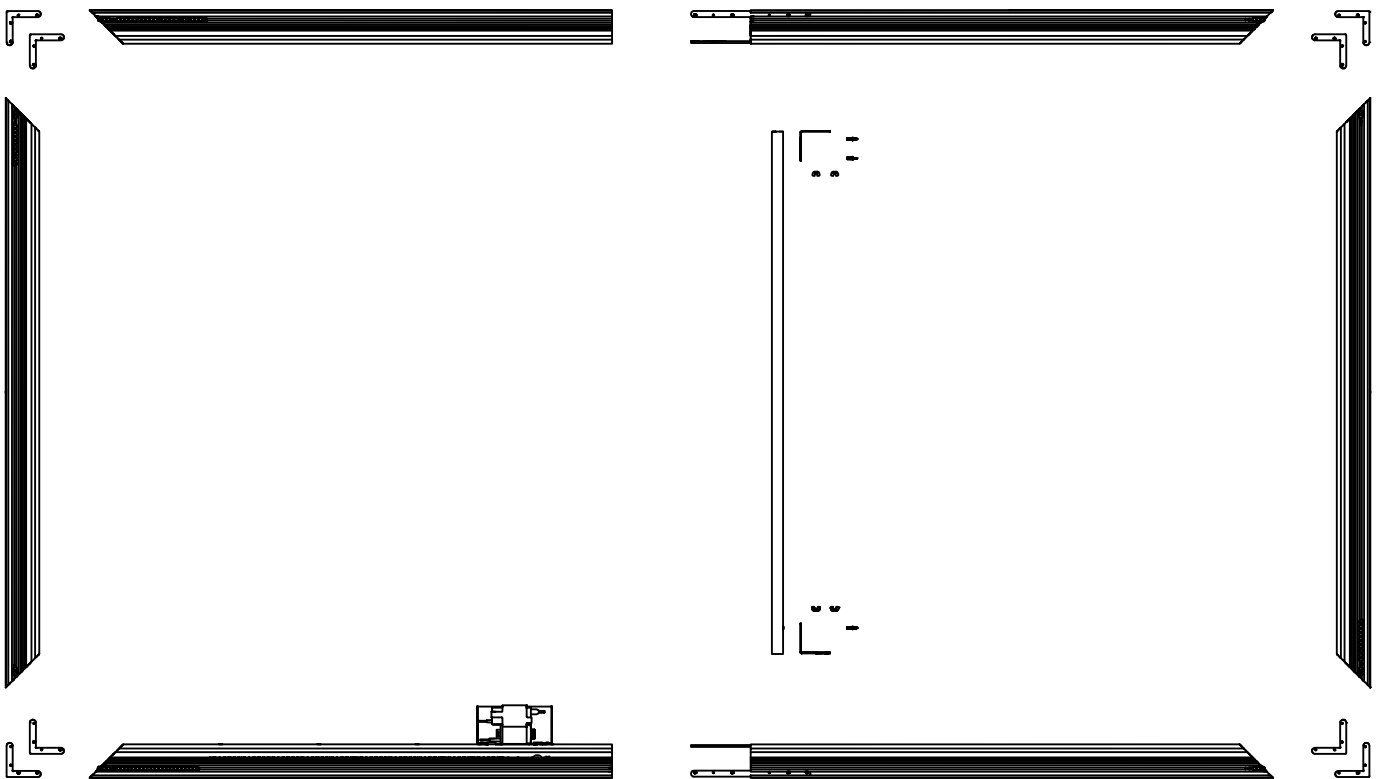

# SPLIT FRAME ASSEMBLY

1

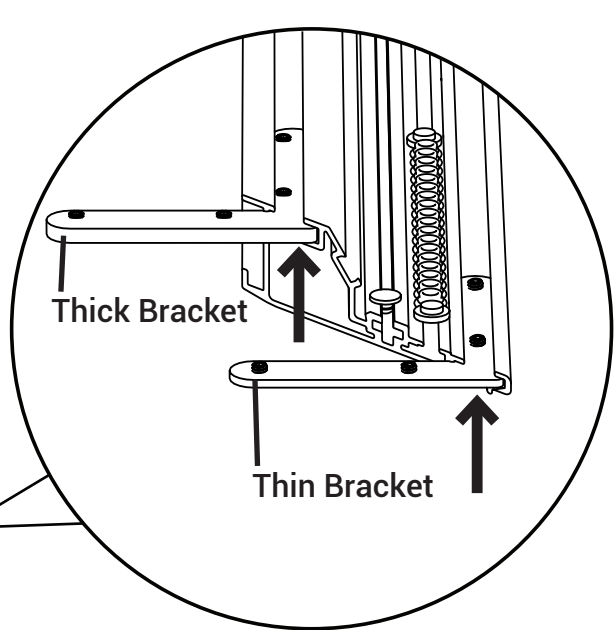
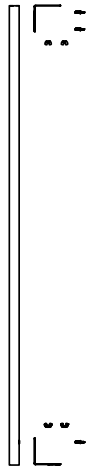
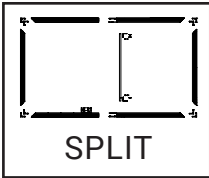

2

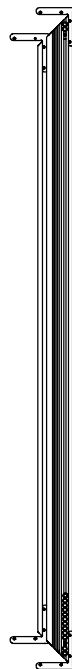

Insert the thin corner brackets into the outside channels and the thick corner brackets into the inside channels of the vertical frames. Then slide into the channels in the horizontal frames.

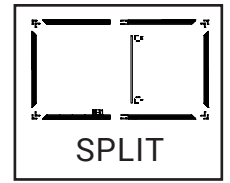

3

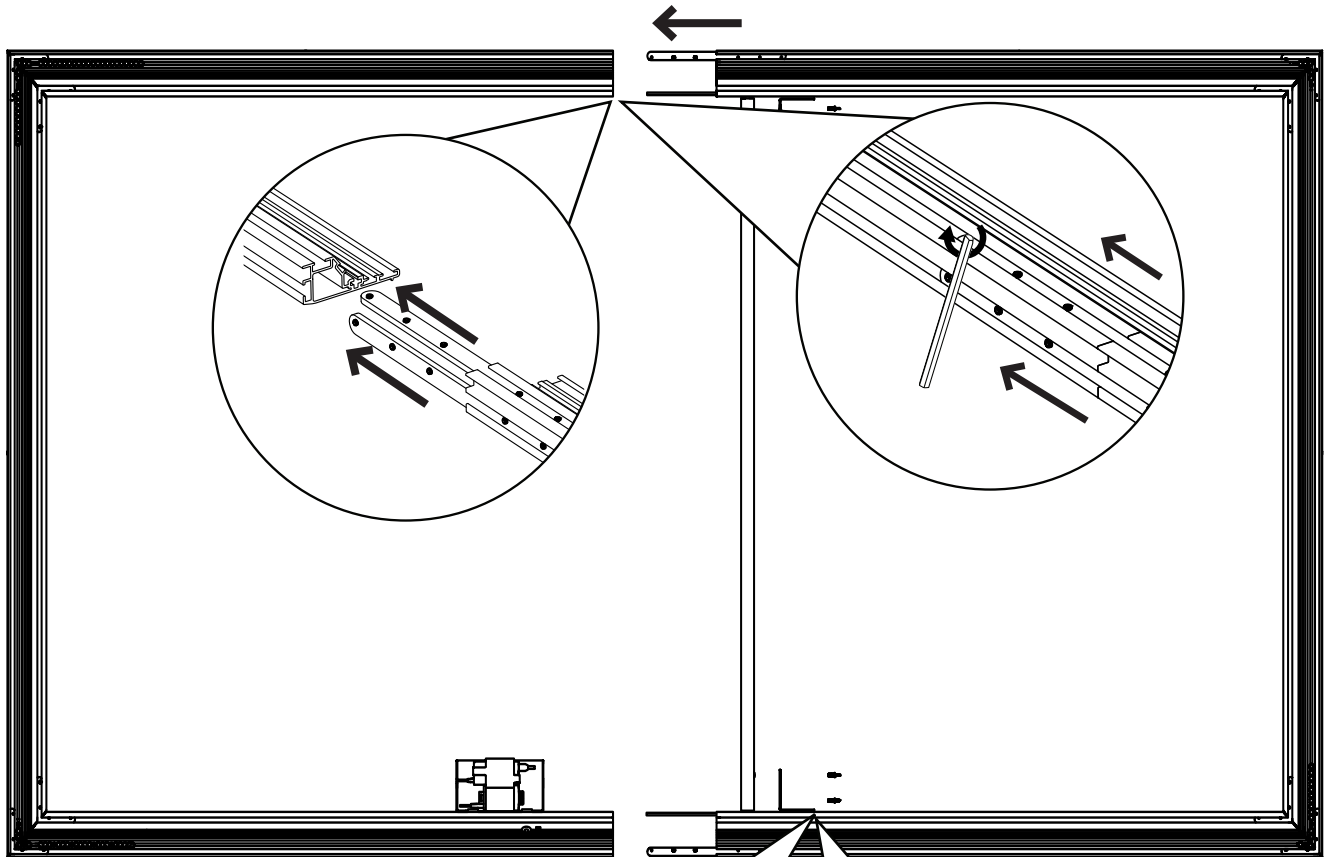

4

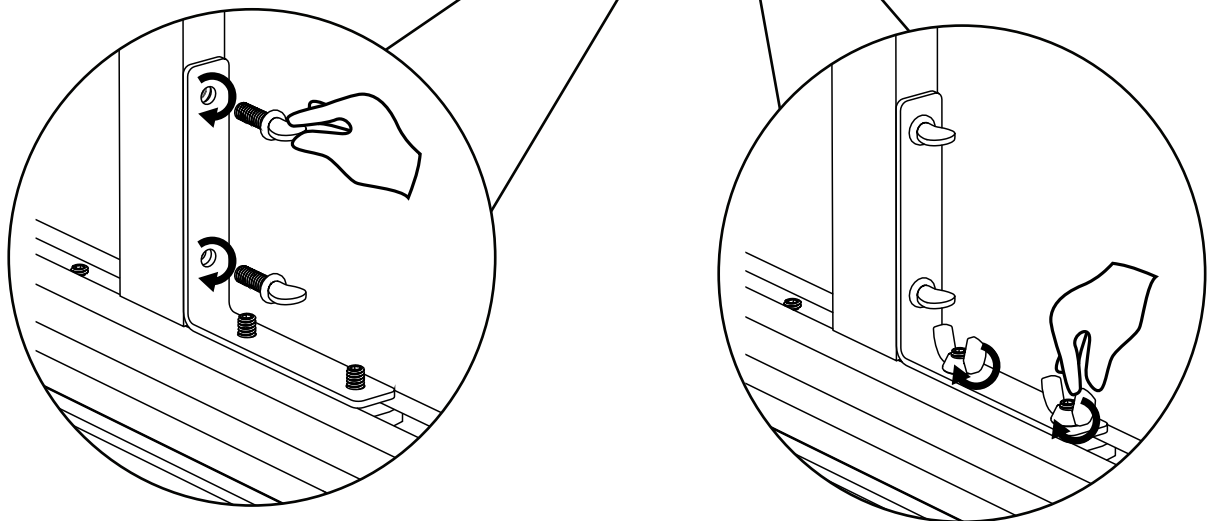

Slide the horizontal frame pieces together and secure with the splice bars. Then attach the vertical support to the frame as shown.

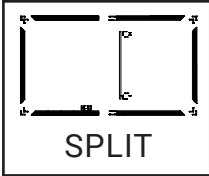

5

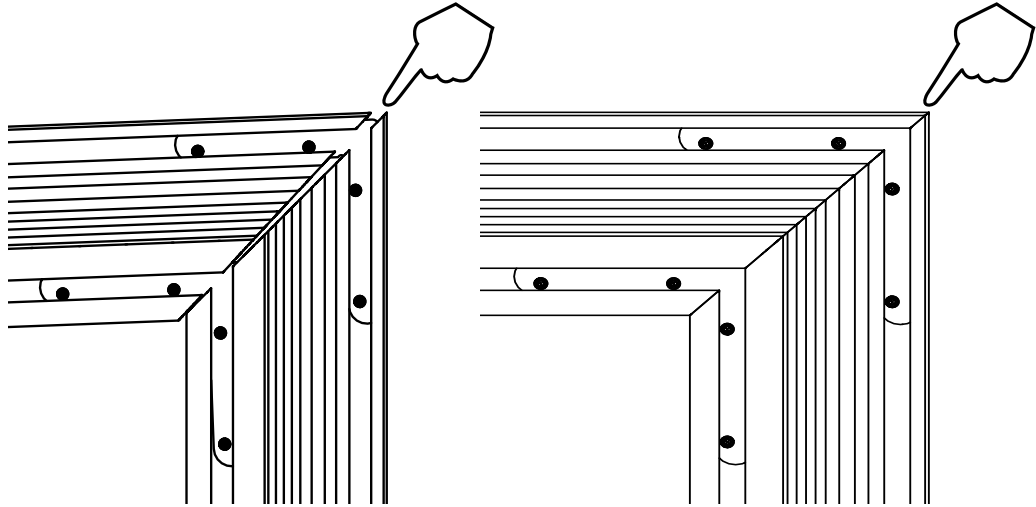

6

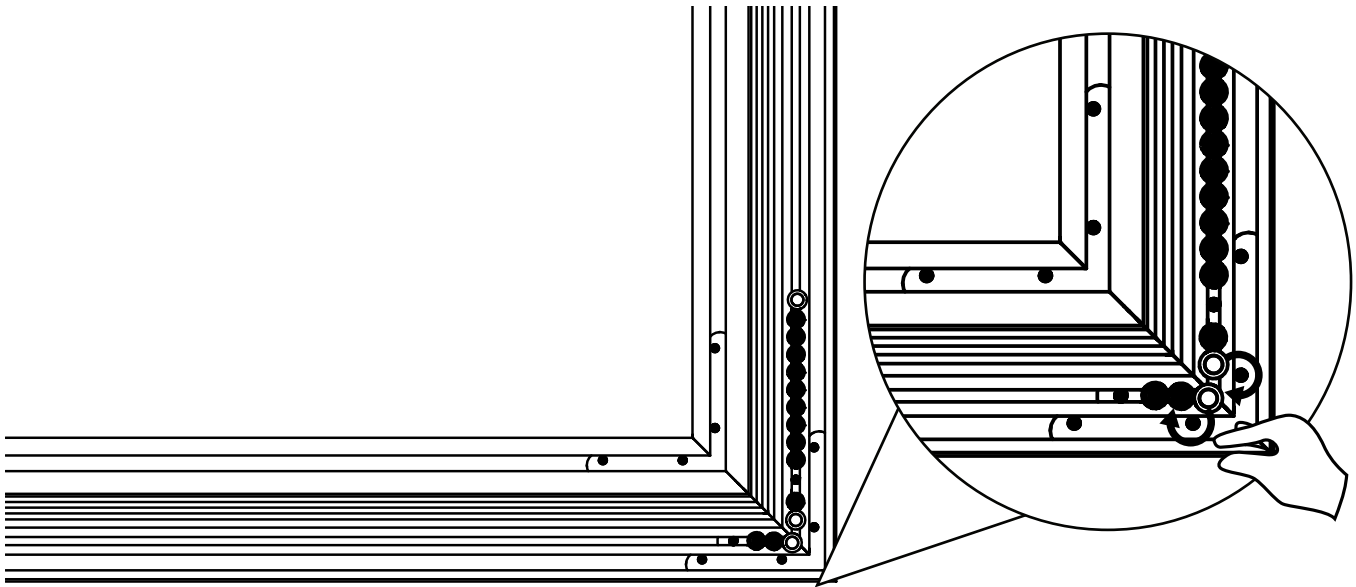

Make sure the points on the frame pieces line up. Then finger tighten 2 of the set screws to lock in the corners.



7

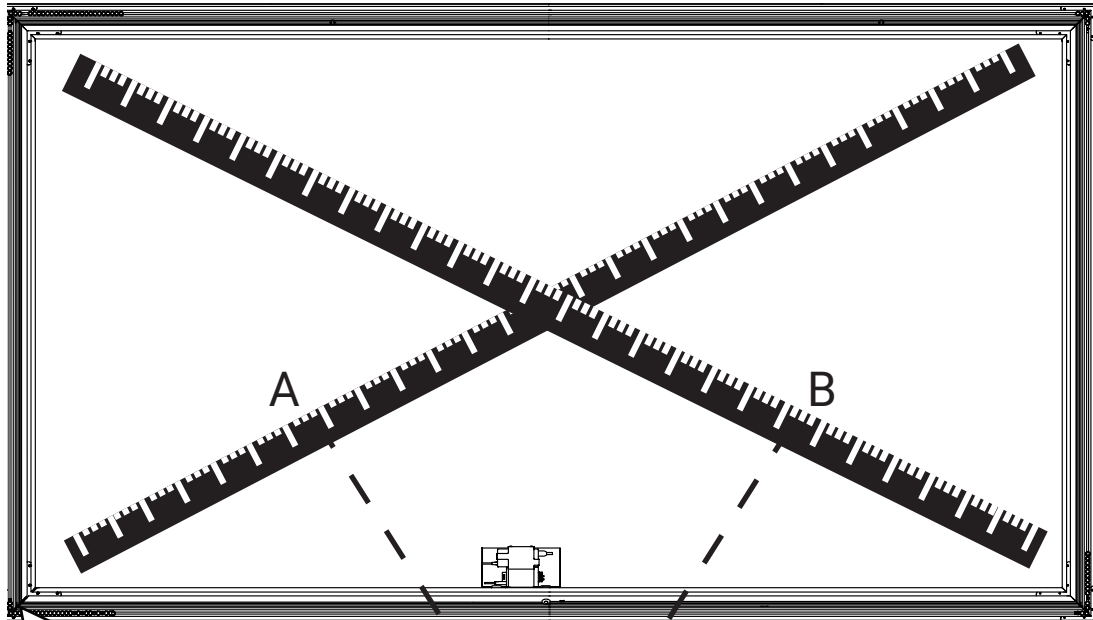
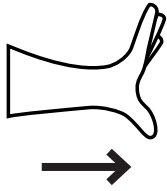
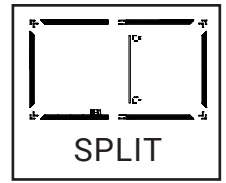
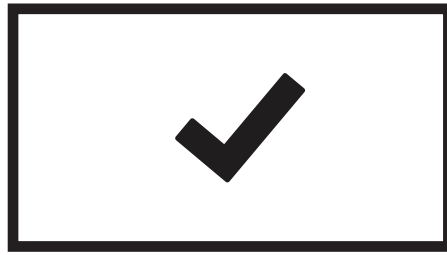
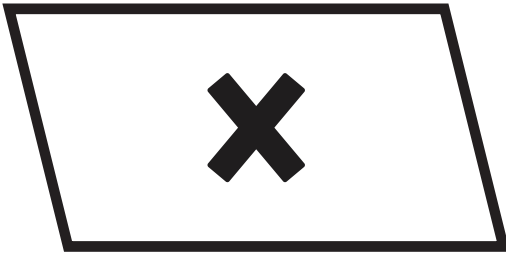

A = B

8

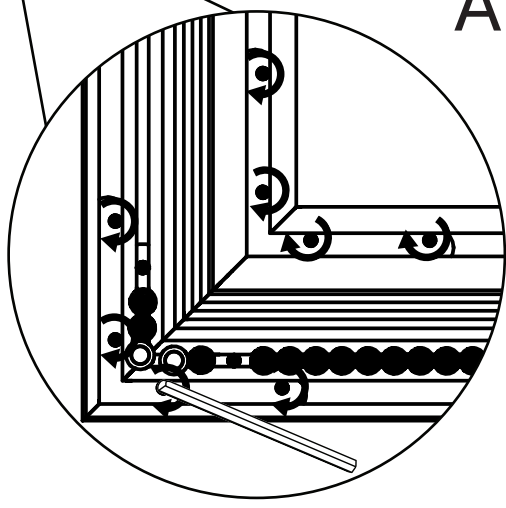

Measure the diagonals to check if frame is square. If one diagonal is longer then push on the corners at that diagonal. Tighten all set screws once the diagonals are equal to within 1/8".

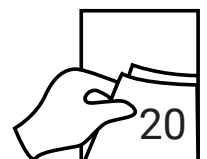



If IP controlled LED lights are ordered, Phillips Hue hub must be purchased and set up separately, see page 50 for IP lighting Instructions.

NOTE: Steps 1 and 2 will have already been completed if possible to be shipped that way. If so skip to step 3.

1

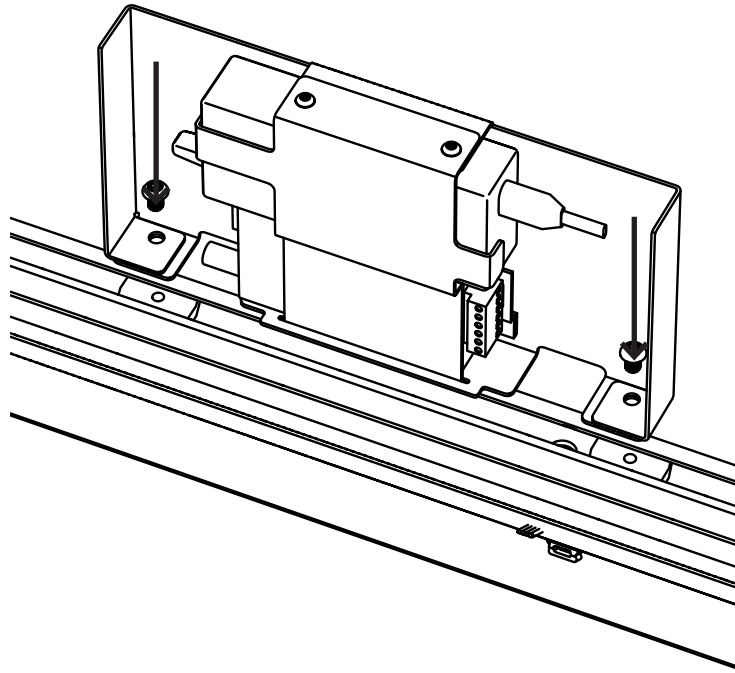

Connect the lighting harness with the included screws to the nuts in the frame piece with the lights attached to it.

2

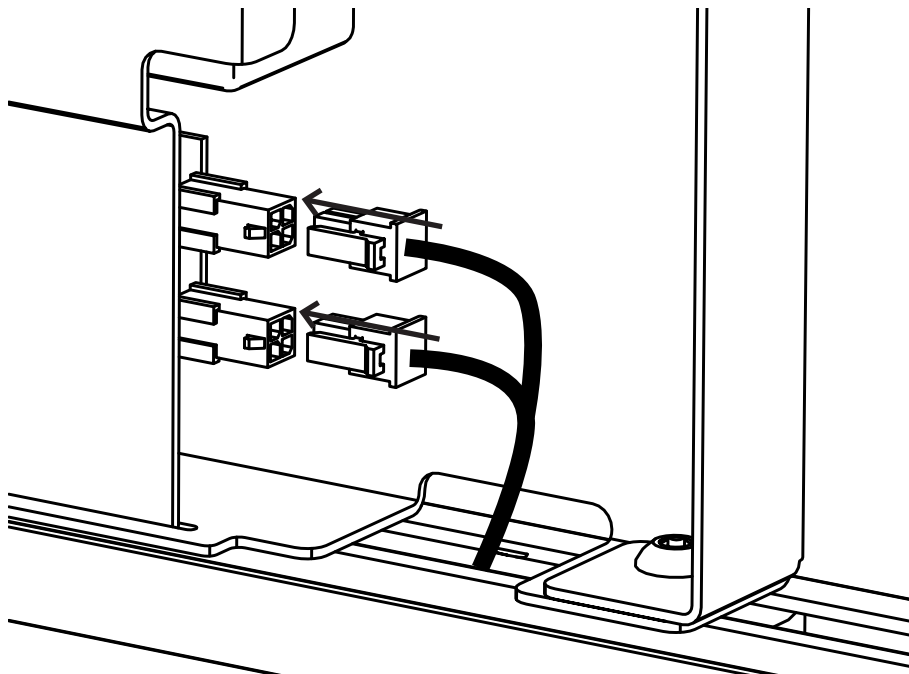

Plug in the lights to the controller plugs.

3

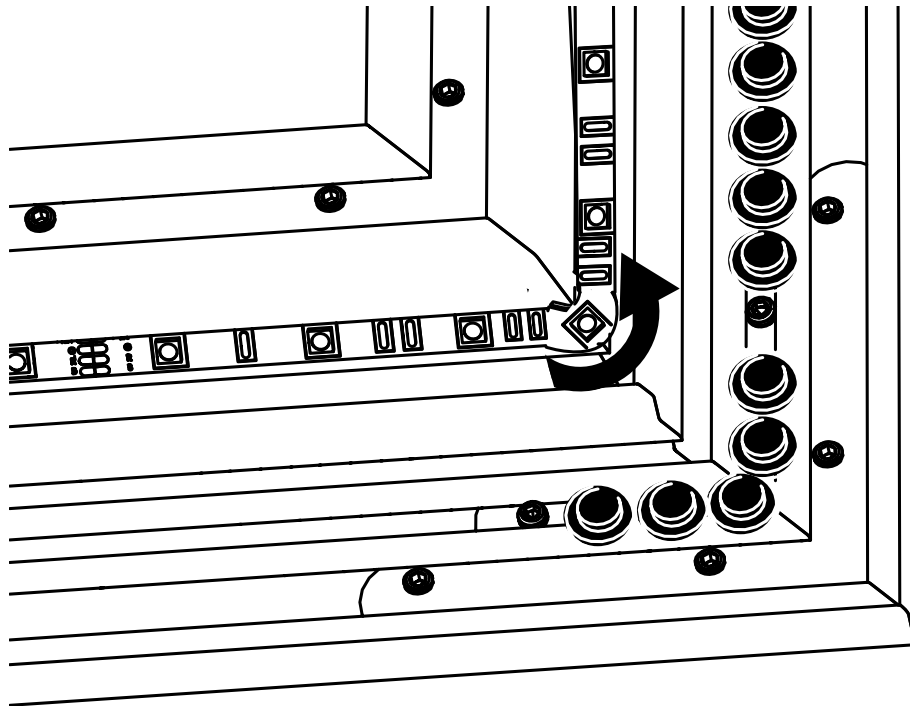
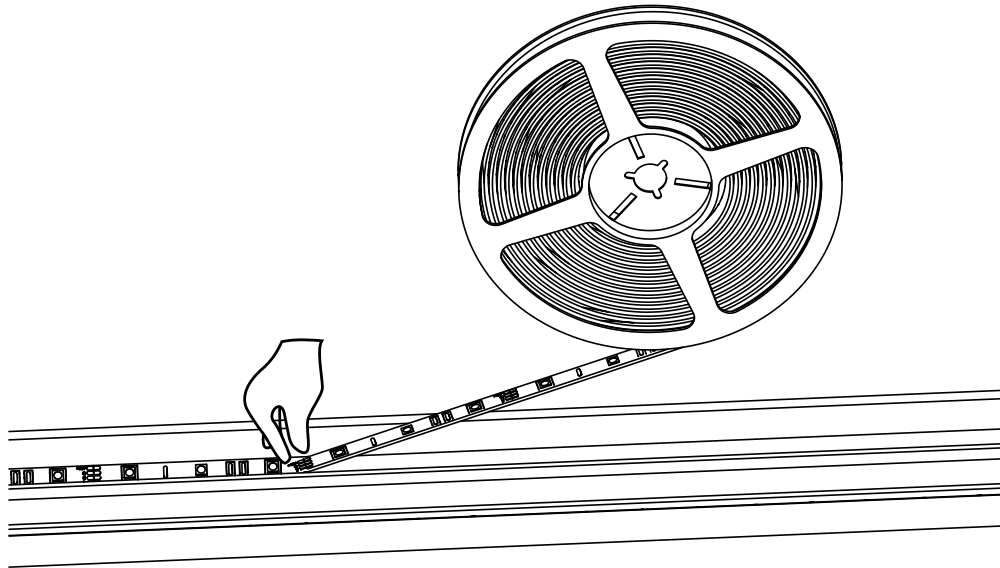

Press in the lights to the channel on the frame. Do not crease the lights at the corners.

BLACK DIAMOND or  
SHORT THROW

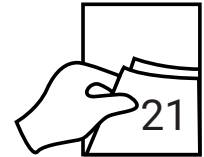

SLATE or PURE

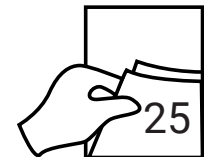

MAESTRO

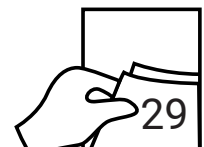



Black diamond and short throw material are highly sensitive. Take care to not bend or crease the material as you unroll it.

1

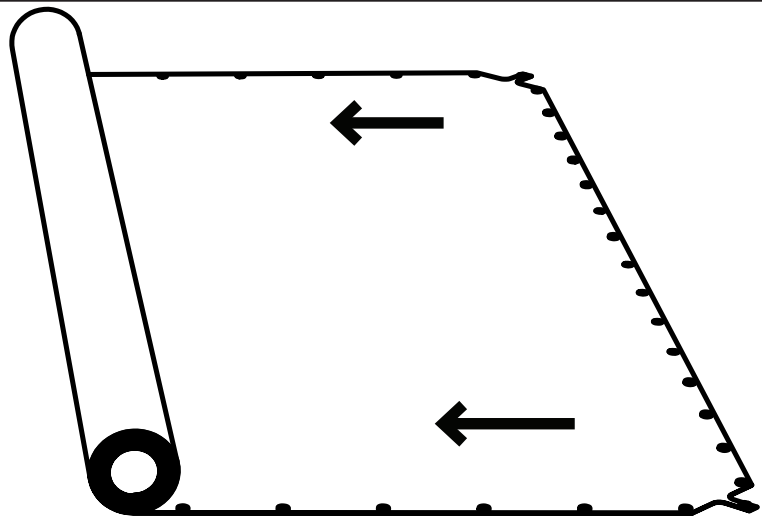
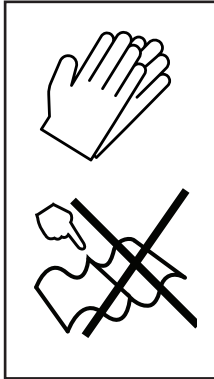

Wear gloves when handling material. Carefully unroll the screen material out onto a clean floor. Take care to not bend or crease the screen material.

2

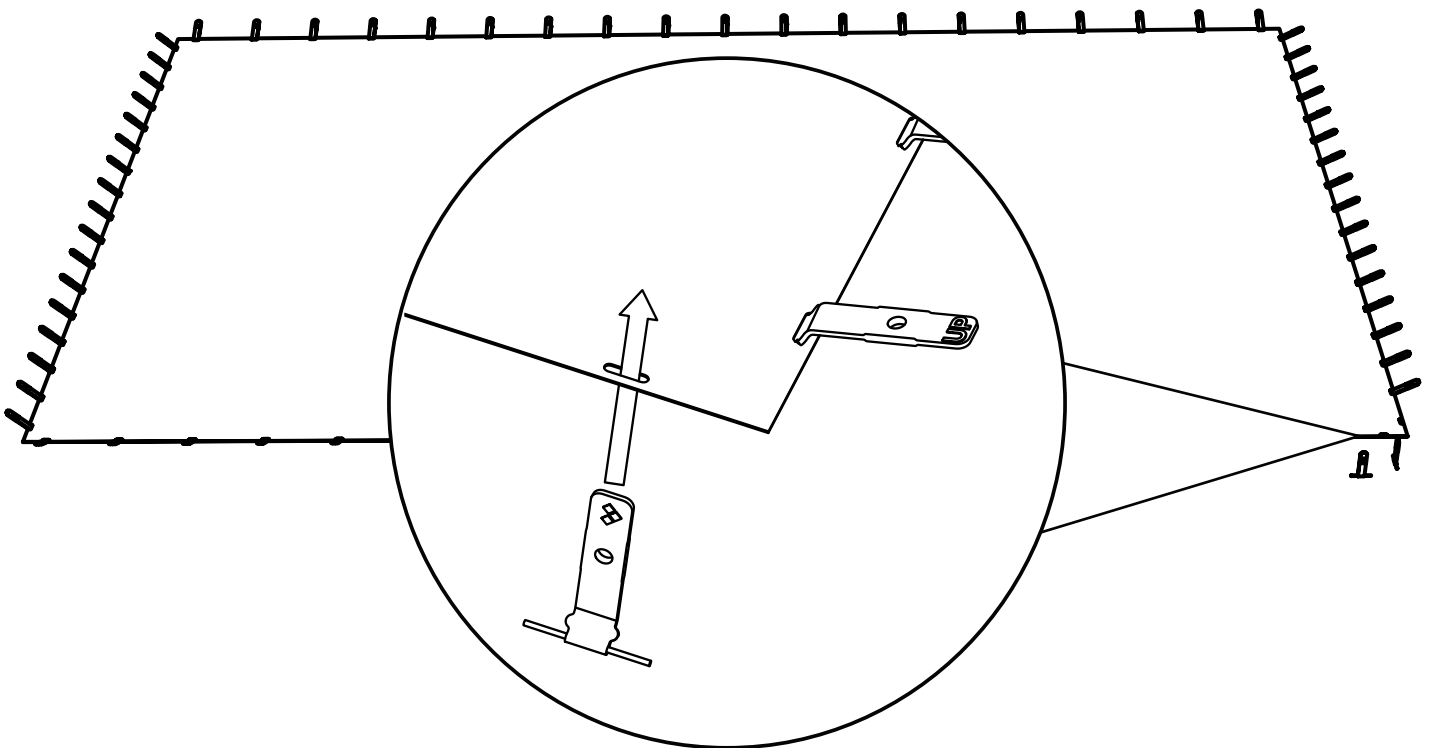

Insert the BD attaching bands up through the slots in the material. Note the orientation of the bands such that the bent band will naturally lie away from the material and the UP label is visible.



DO NOT drop the frame onto the screen material. Frame must be gently set down onto the screen material to avoid denting the material.

3

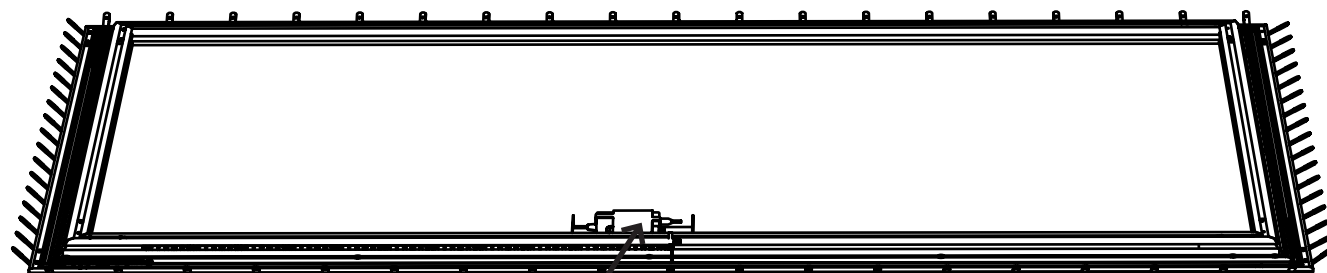
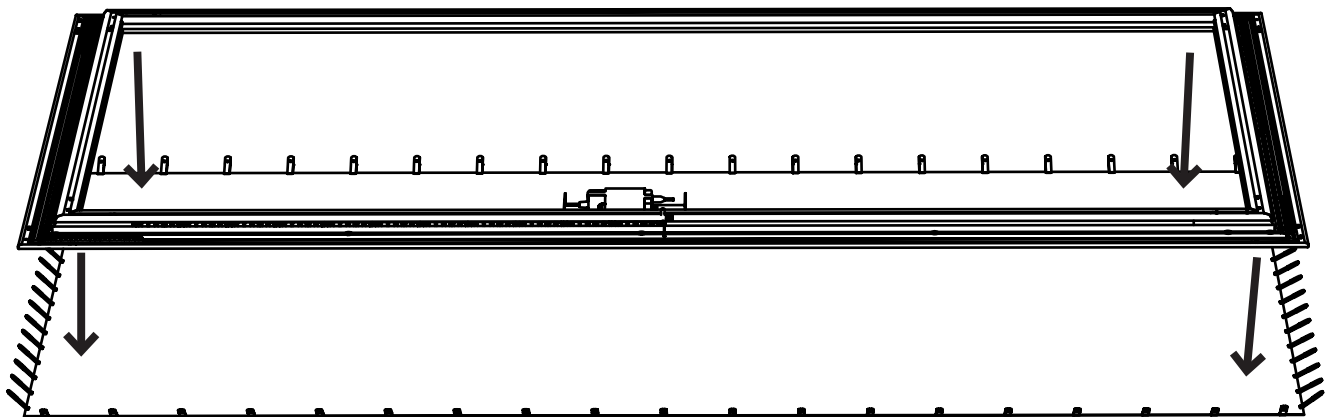

For Short Throw  
LED harness at bottom

Carefully lie the frame onto the screen material making sure to not dent the screen material with the frame or frame corners. Align the edges of the screen material with the edges of the frame.

NOTE: For short throw material make sure the material is oriented such that the LED harness is at the bottom of the screen material.

4

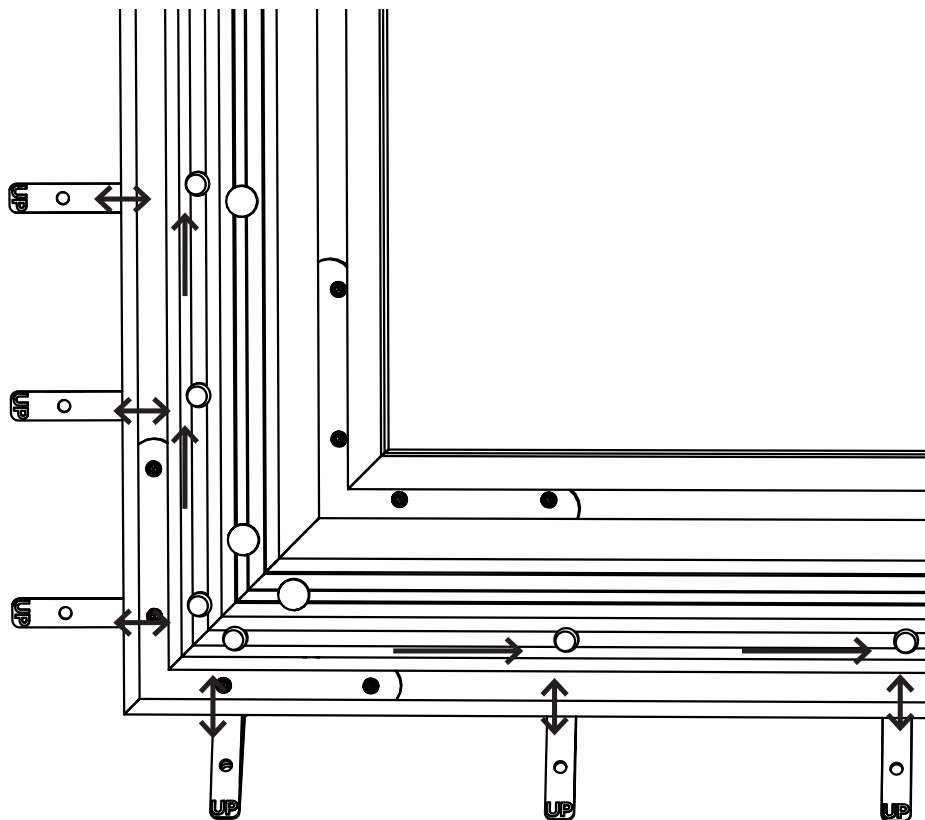

Remove and discard the black retaining bumpers then spread out the posts so that they align with the attaching bands.

5

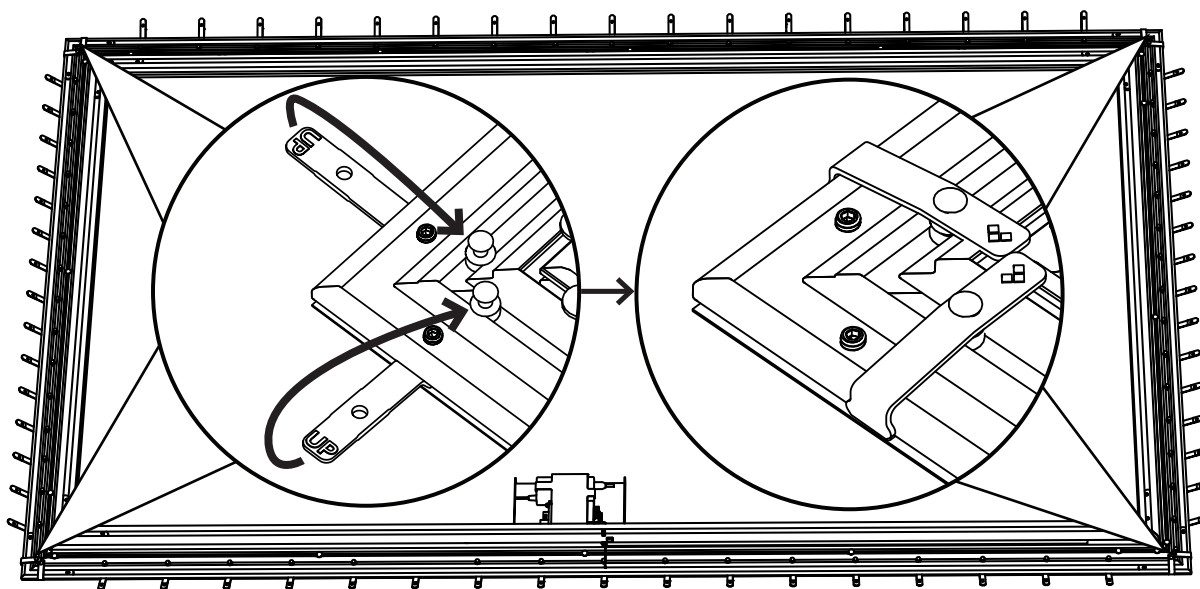

Pull up and then over on the bands to attach to the posts so that the SI diamonds are showing. Do this at all 4 corners before proceeding. Make sure the screen material is **centered about the frame** by making sure the edges of the screen material line up with the edges of the frame.



As you continue to attach the bands make sure the material is centered about the frame. This is easy to tell by making sure the edge of the material is flush with the edge of the frame.

6

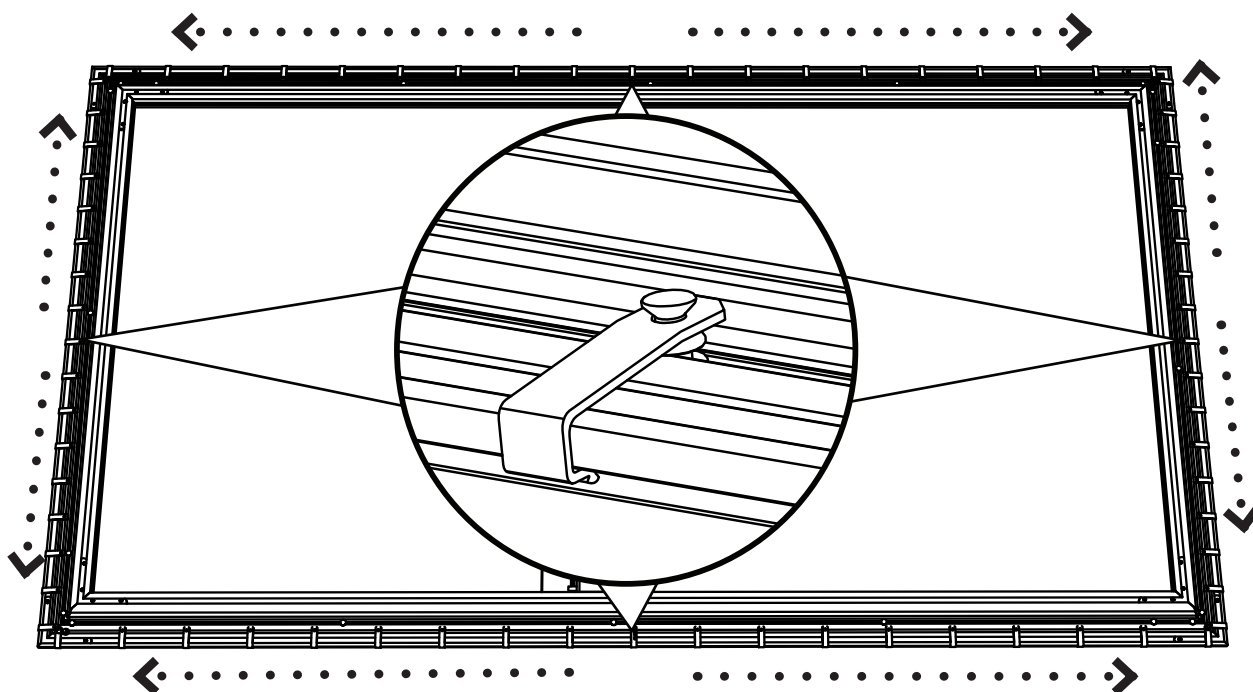

Attach the bands at the middle and then work your way towards the ends on all 4 sides of the screen material. Once all bands are attached **flip screen over and make sure that the screen material is flat and tight everywhere.**





1

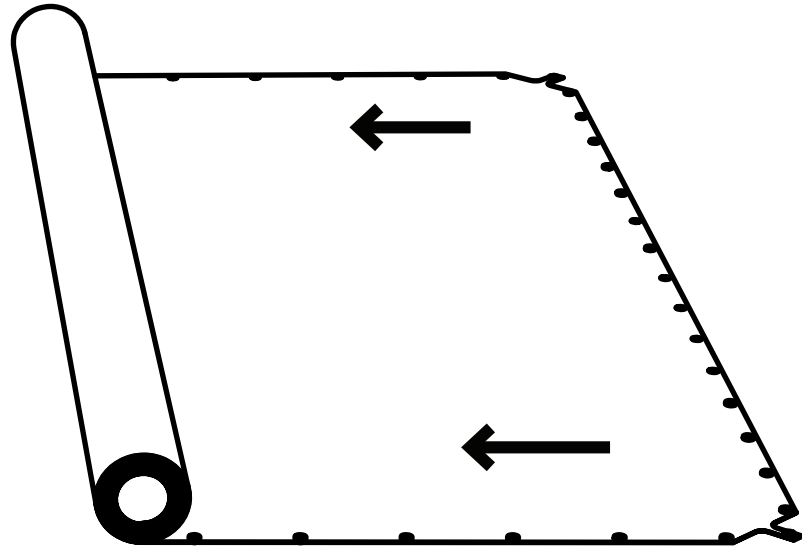
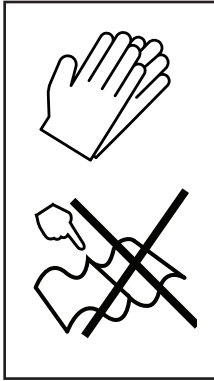

Wear gloves when handling material. Carefully unroll the screen material out onto a clean floor. Take care to not bend or crease the screen material.

2

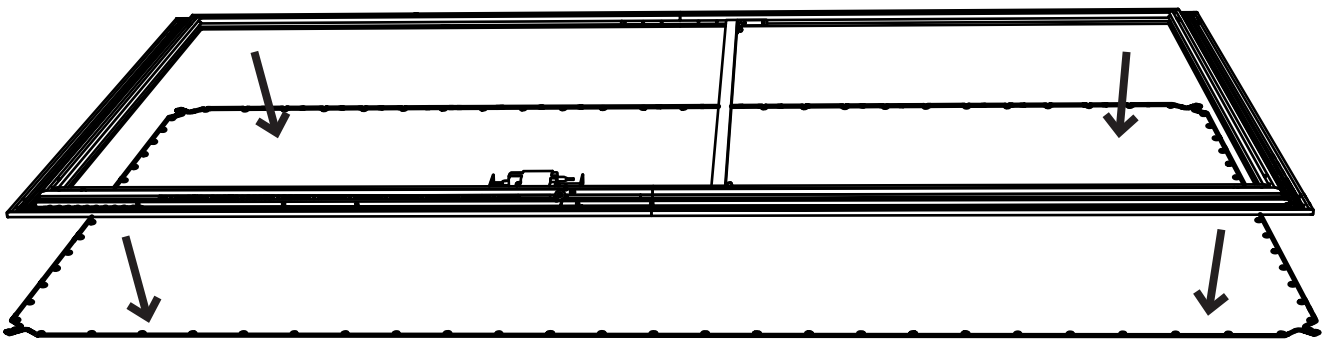

Carefully lie the frame onto the screen material. Center the frame about the screen material.

3

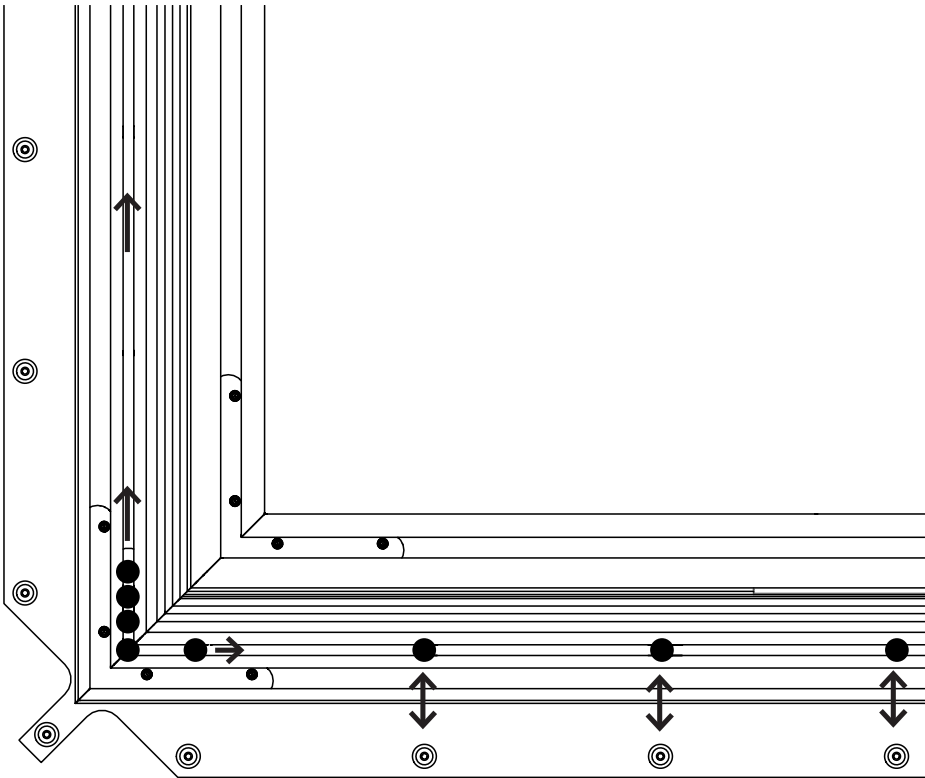

Remove and discard the black retaining bumpers then spread out the posts so that they aligning with the snaps on the screen material.

4

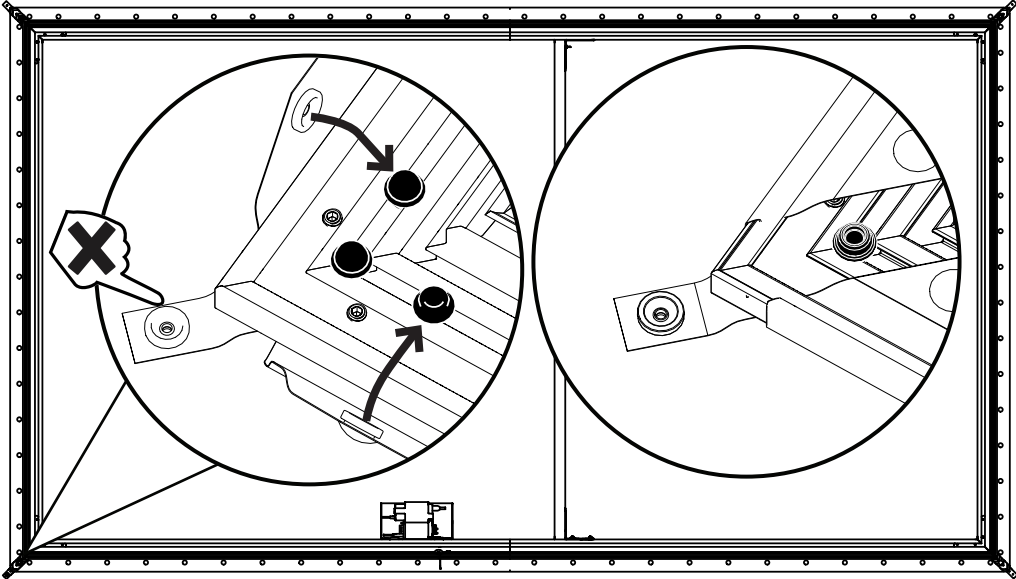

At all 4 corners attach the snaps at the end of screen material but NOT the snap on the corner tab. **Make sure the screen material is centered about the frame before proceeding**

5

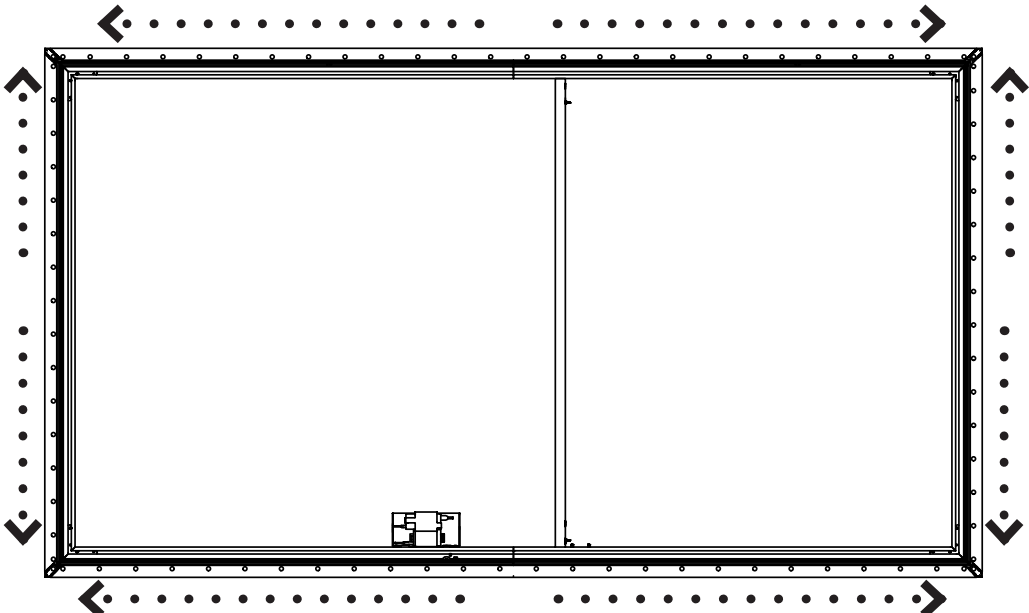

Attach the snaps at the middle and then work your way towards the ends on all 4 sides of the screen material.

6

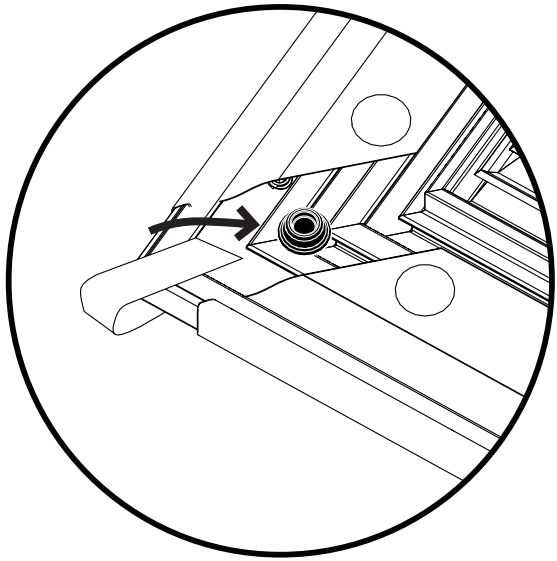

Finally attach the snaps at the corner tabs. Then check to make sure the screen material is flat and adjust the snap positions if necessary to flatten the screen material. Once all snaps are attached **flip screen over and make sure that the screen material is flat and tight everywhere.**

## For AT Material Only

7

Acoustically Transparent (AT) materials come with a black backer that must be installed to eliminate shine through.

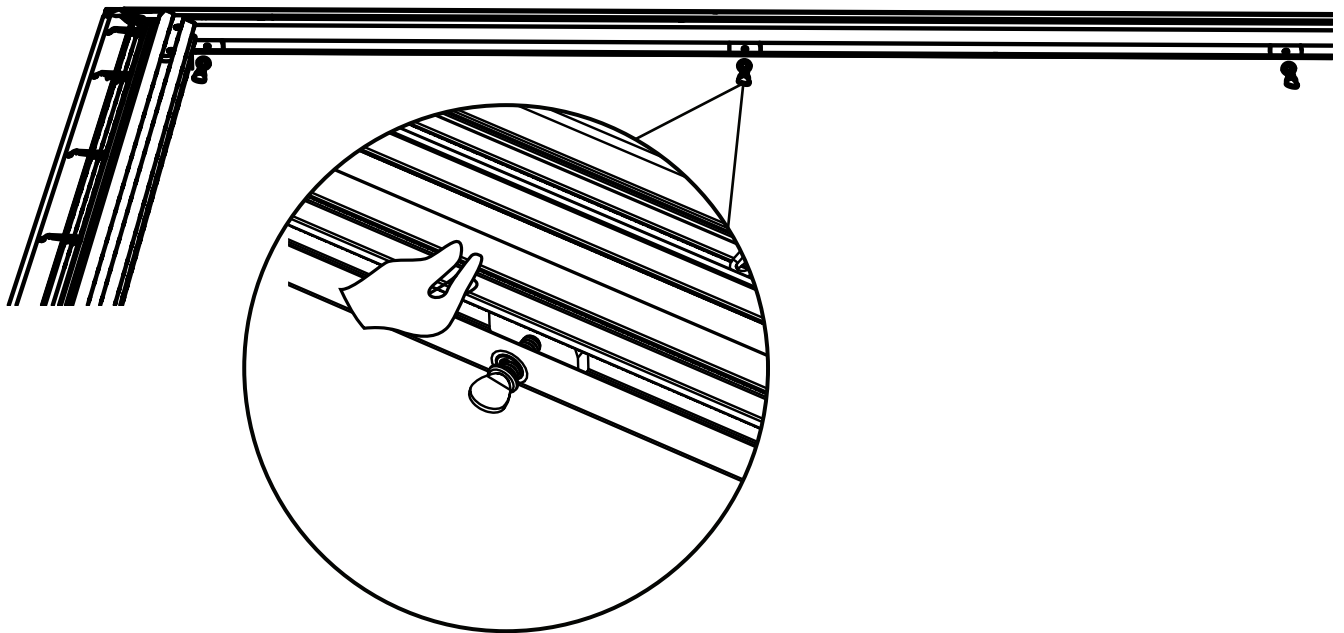

Spread out the nuts in the top frame piece and attach the black backer to the nuts with the thumb screws. **Flip screen over and make sure that the screen material is flat and tight everywhere.**

Note: If the notch in the black backer is not aligned with the vertical support then flip it over.

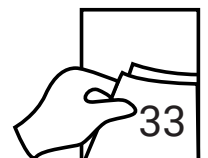

1

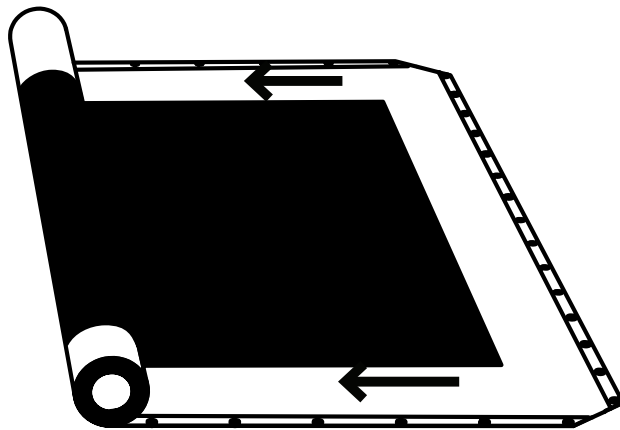
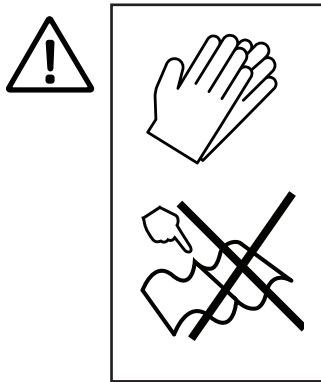

Wear gloves when handling material. Carefully unroll the screen material out onto a clean floor. Take care to not bend or crease the screen material.

2

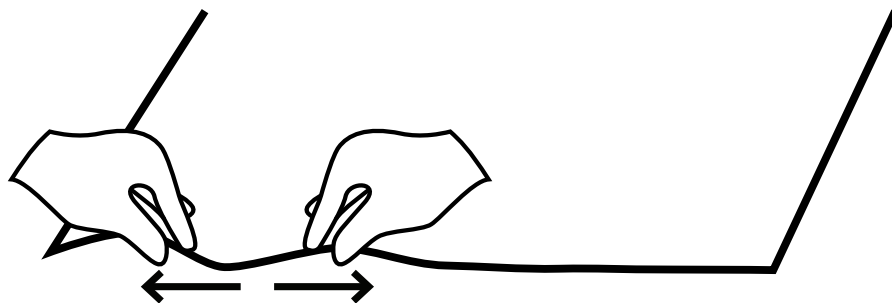
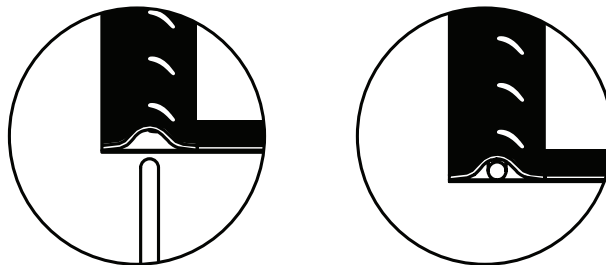

Insert the rods into the pocket in the screen material. Make sure the screen material is lying flat. If the screen material is bunched up at the rods then work from the middle out spreading out the screen material until it is flat.

3



Carefully lay the frame onto the screen material. Center the frame about the screen material.

4

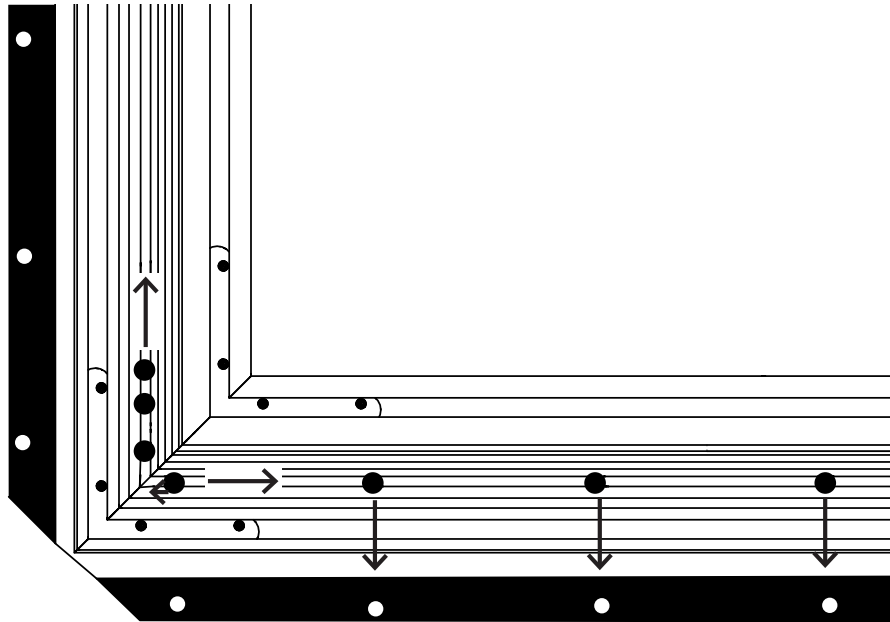

Remove and discard the black retaining bumpers then spread out the posts so that they aligning with the holes in the screen material.

5

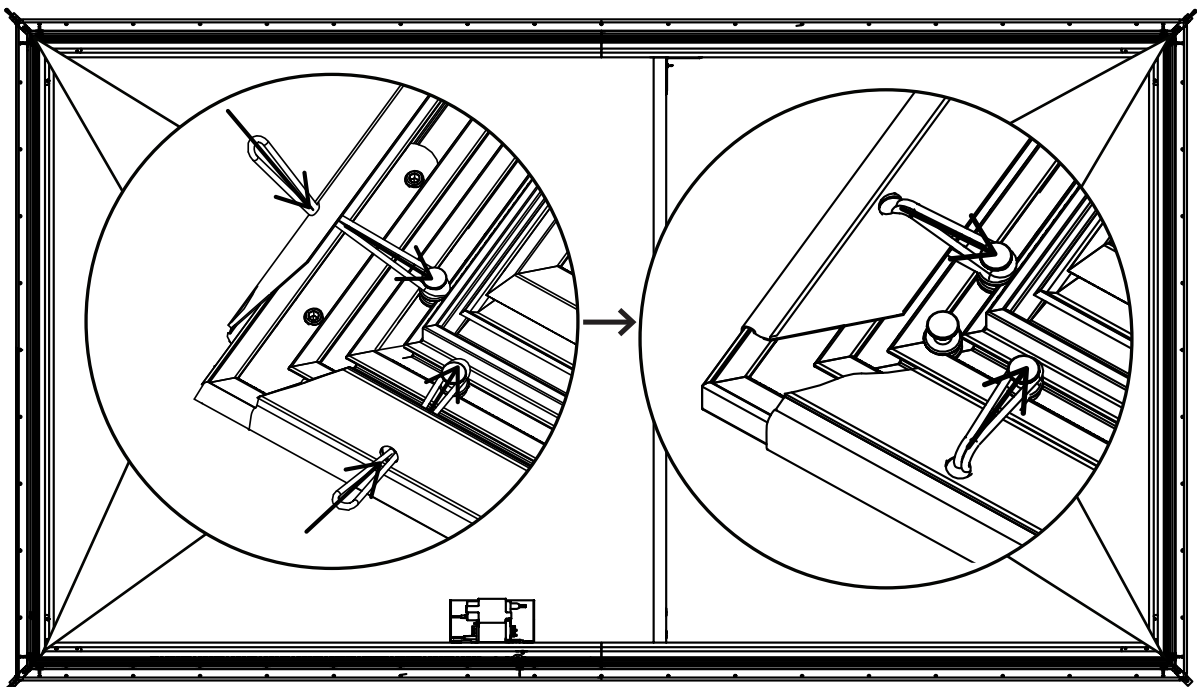

Put one end of the bungee through the hole in the material and place over the post while holding the other end. Then pull the other end of the over the post. Do this at all 4 corners first. **Make sure the screen material is centered about the frame before proceeding.**

6

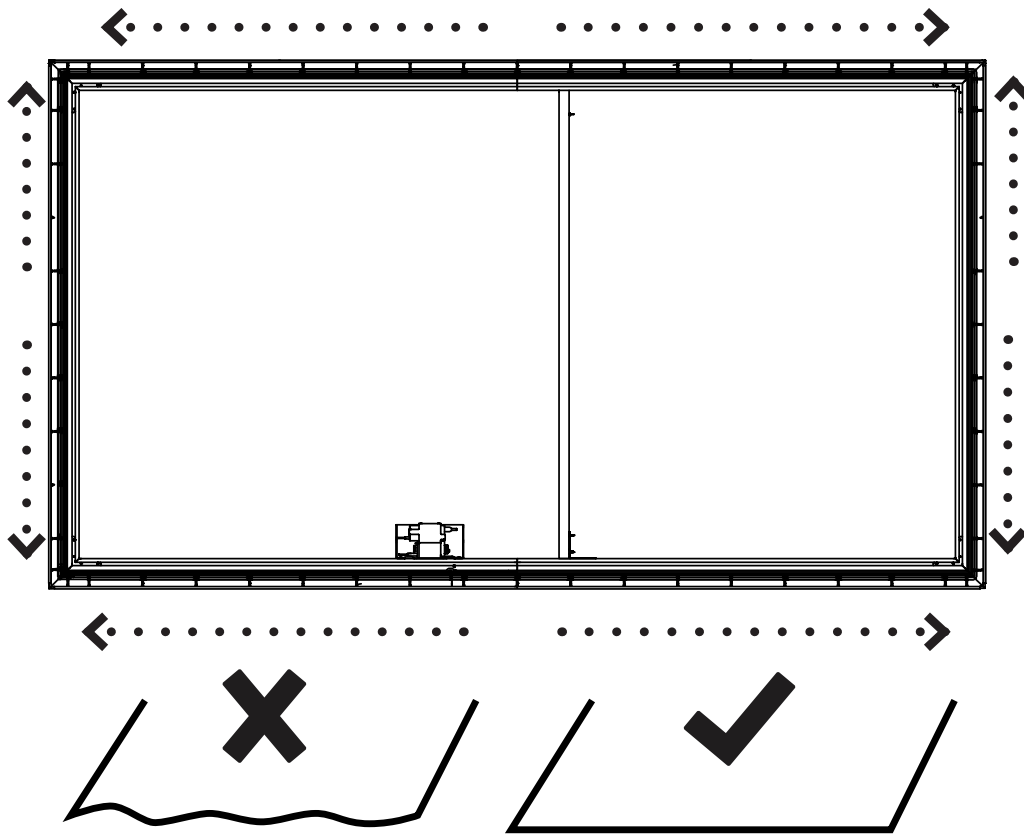

Attach the bungees at the middle and then work your way towards the ends on all 4 sides of the screen material. Check to make sure the screen material is flat and adjust the bungee positions if necessary to flatten the screen material.

**BLACK BACKER ATTACHMENT**

7

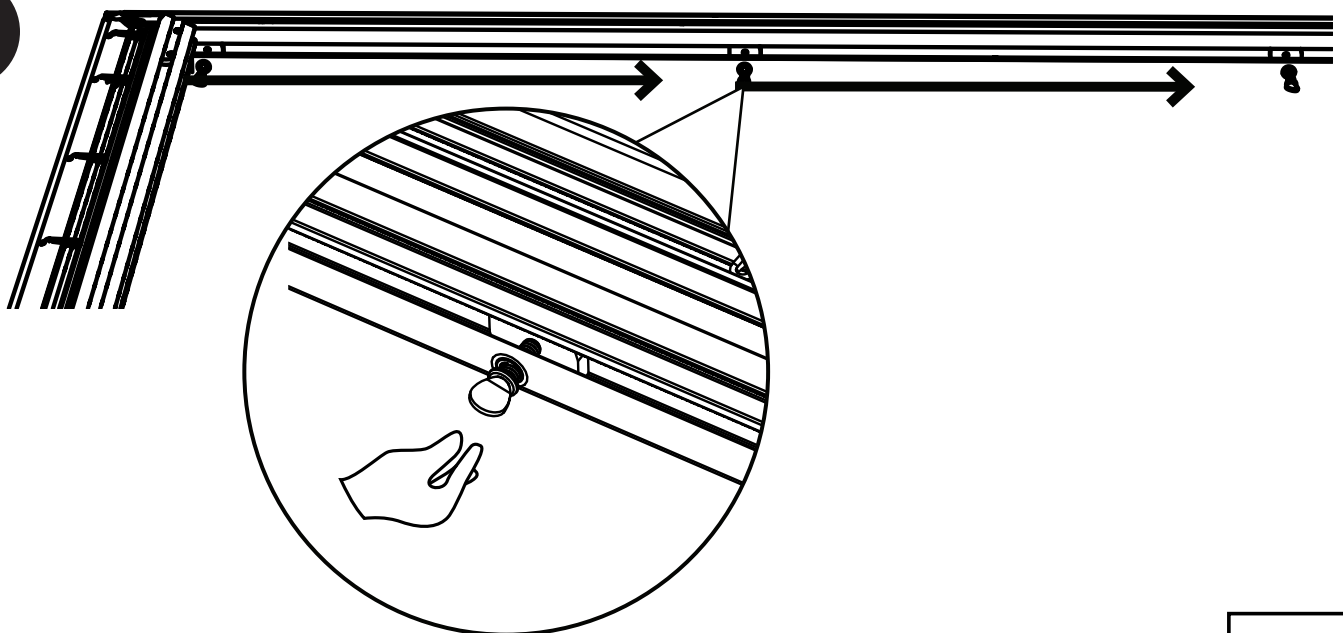

Spread out the nuts in the top frame piece and attach the black backer to the nuts with the thumb screws. **Flip screen over and make sure that the screen material is flat and tight everywhere.**





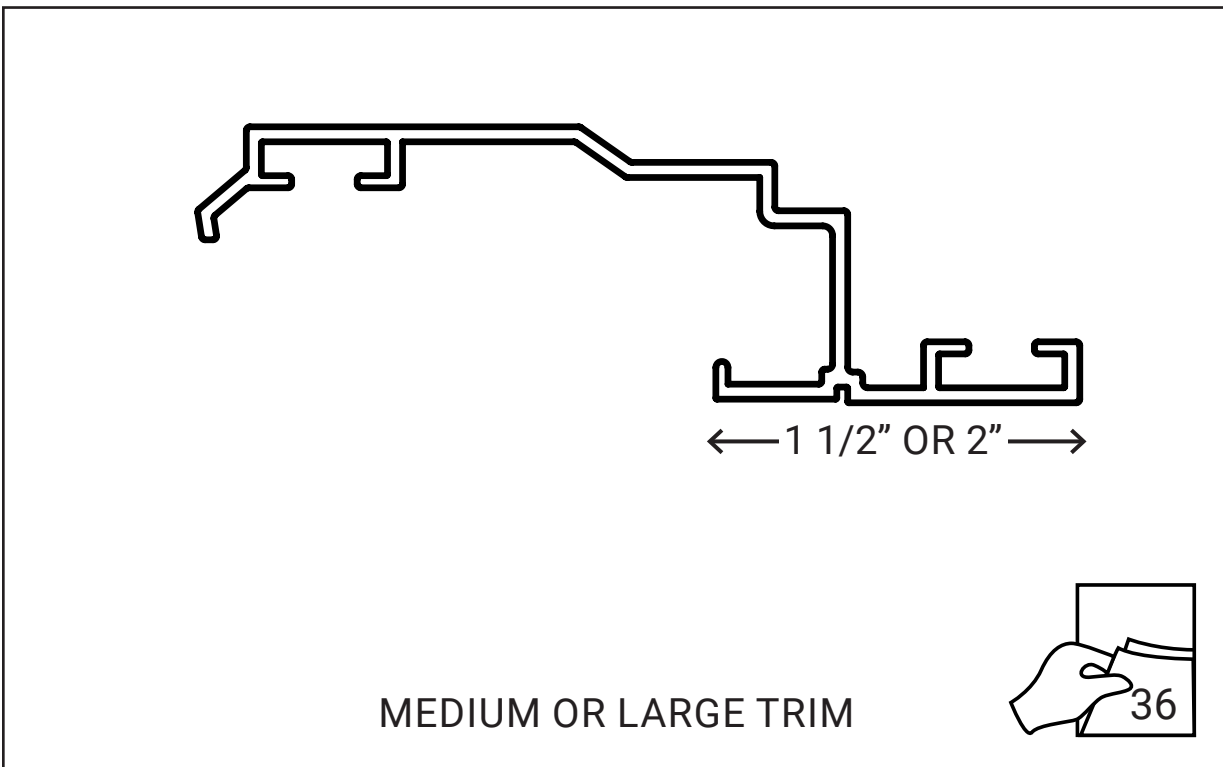
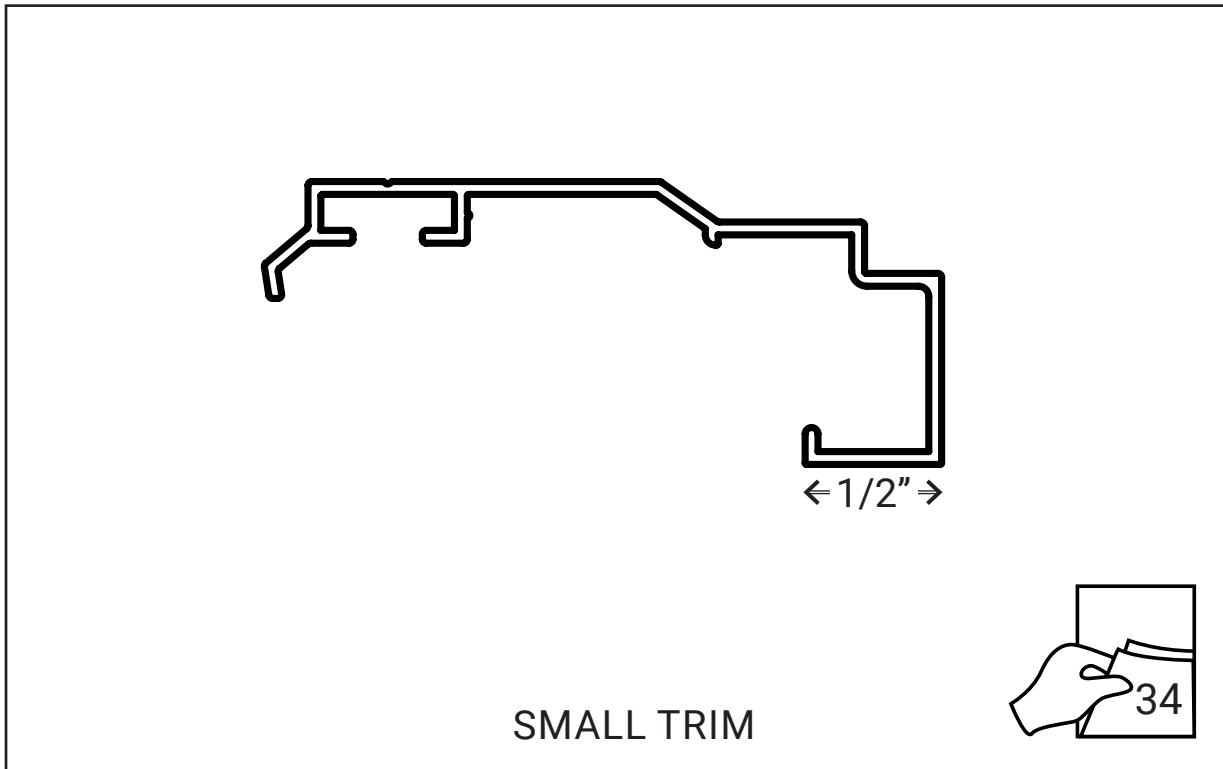



Velvet on trim is delicate, handle with care.

1

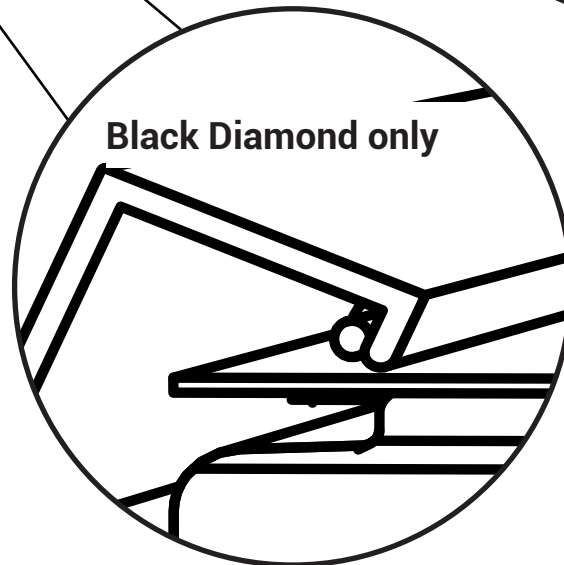
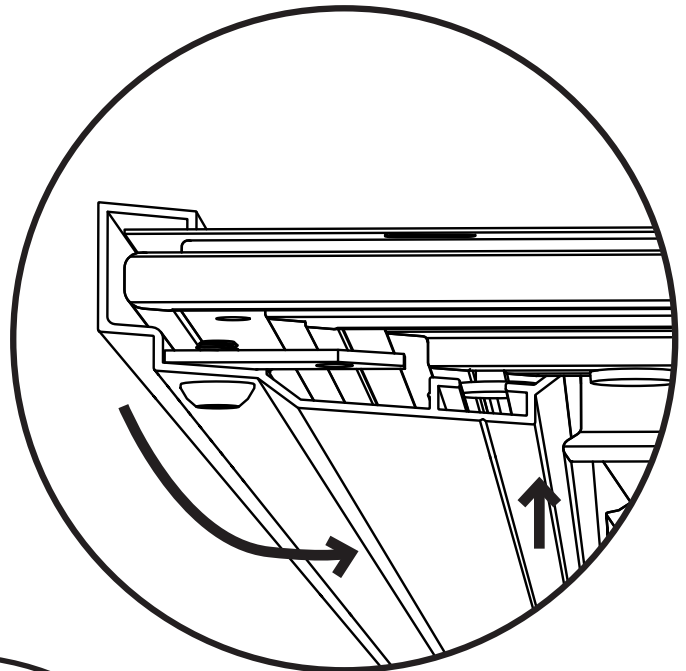
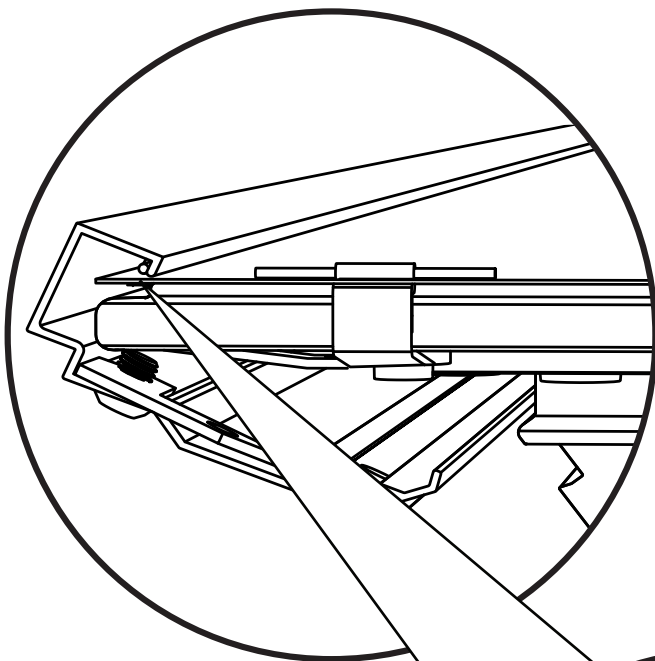

Attach the **vertical trim first** onto the screen as shown above.

**NOTE: For Black Diamond and Short Throw make sure that the front lip of the trim is over the attaching bands before rotating the trim into place.**

2

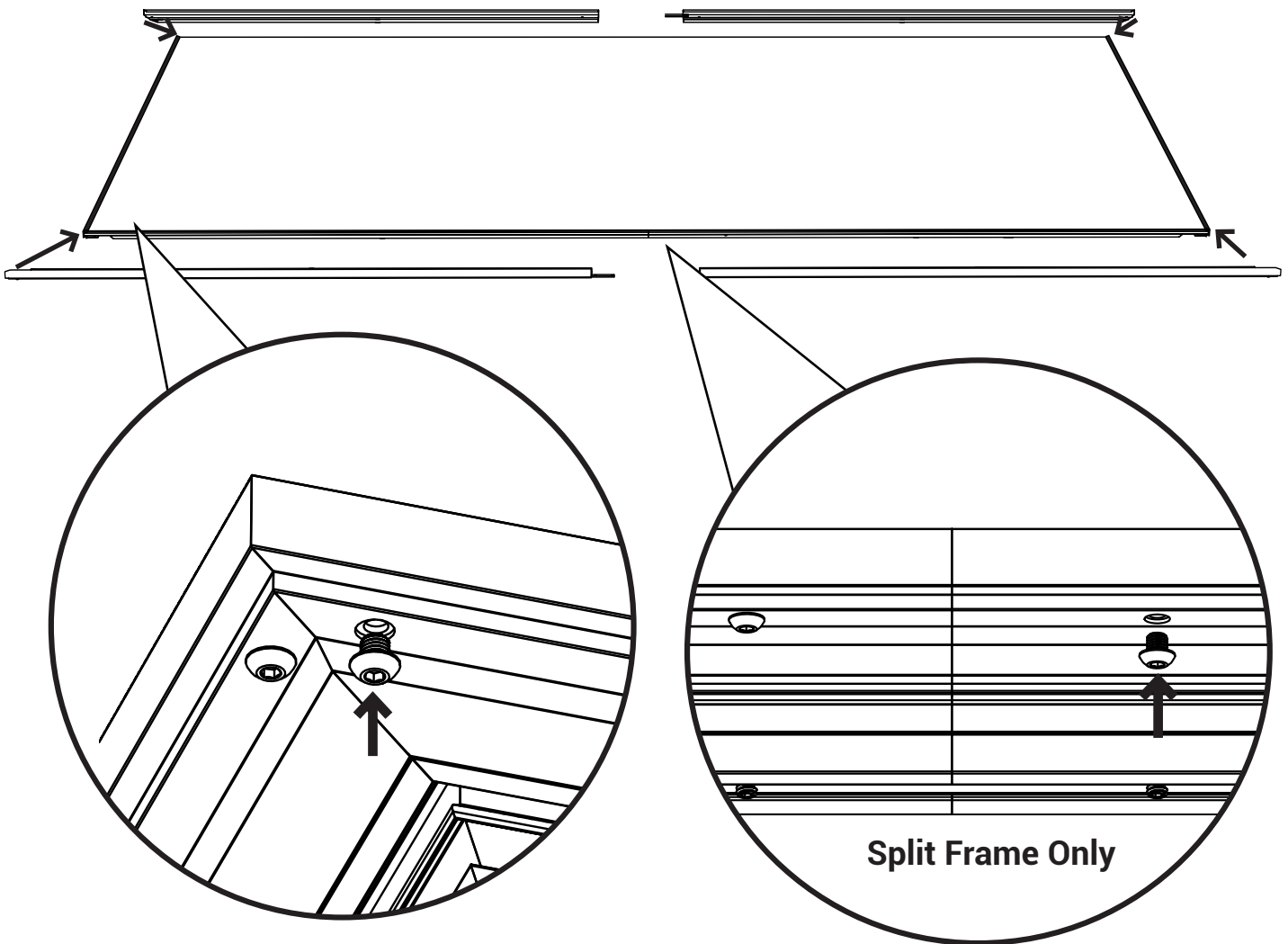

Attach the horizontal trim pieces. Align and secure the corners with the 1/4-20 x 1/4" screws as shown. Hold the trim corners together while tightening the screw to ensure a well aligned corner.

Split Frame Only: Connect the horizontals at the middle by installing 1/4-20 x 1/4" screws trough the trim into the splice bar.





Velvet on trim is delicate, handle with care.

1

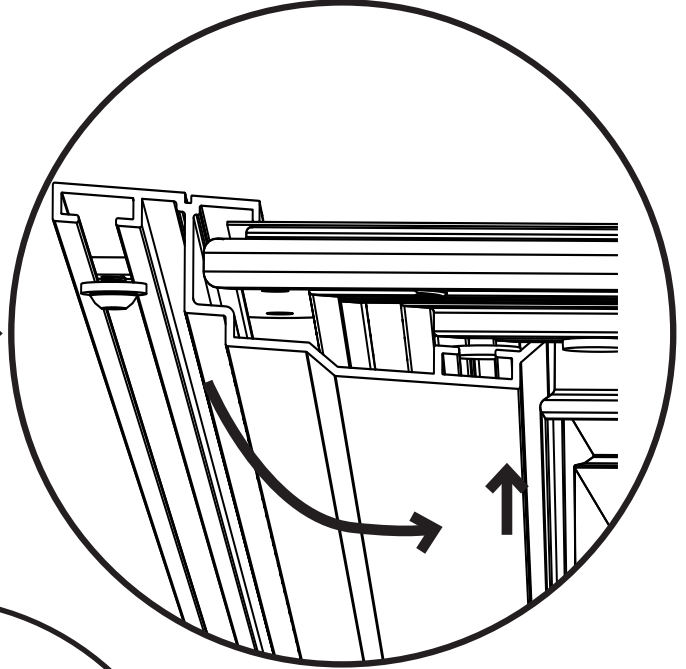
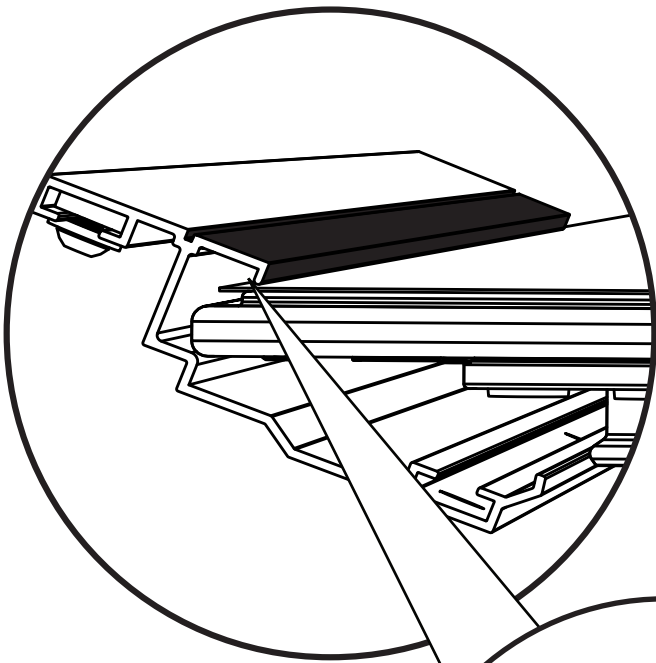
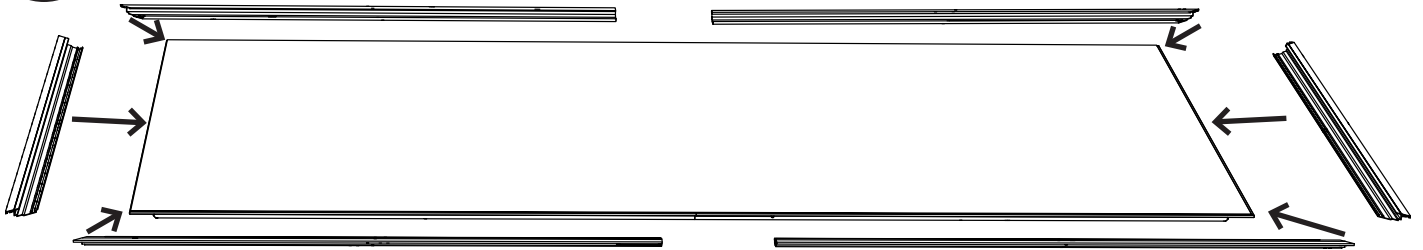

Black Diamond only

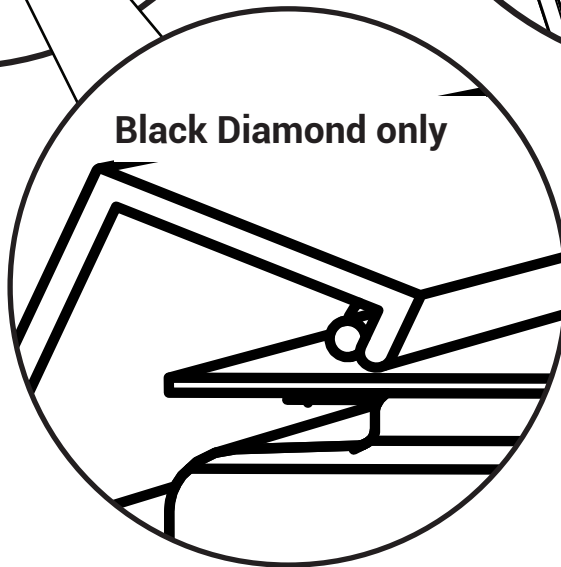

Attach the trim onto the screen as seen above.

**NOTE: For Black Diamond make sure that the front lip of the trim is over the attaching bands before rotating the trim into place.**

2

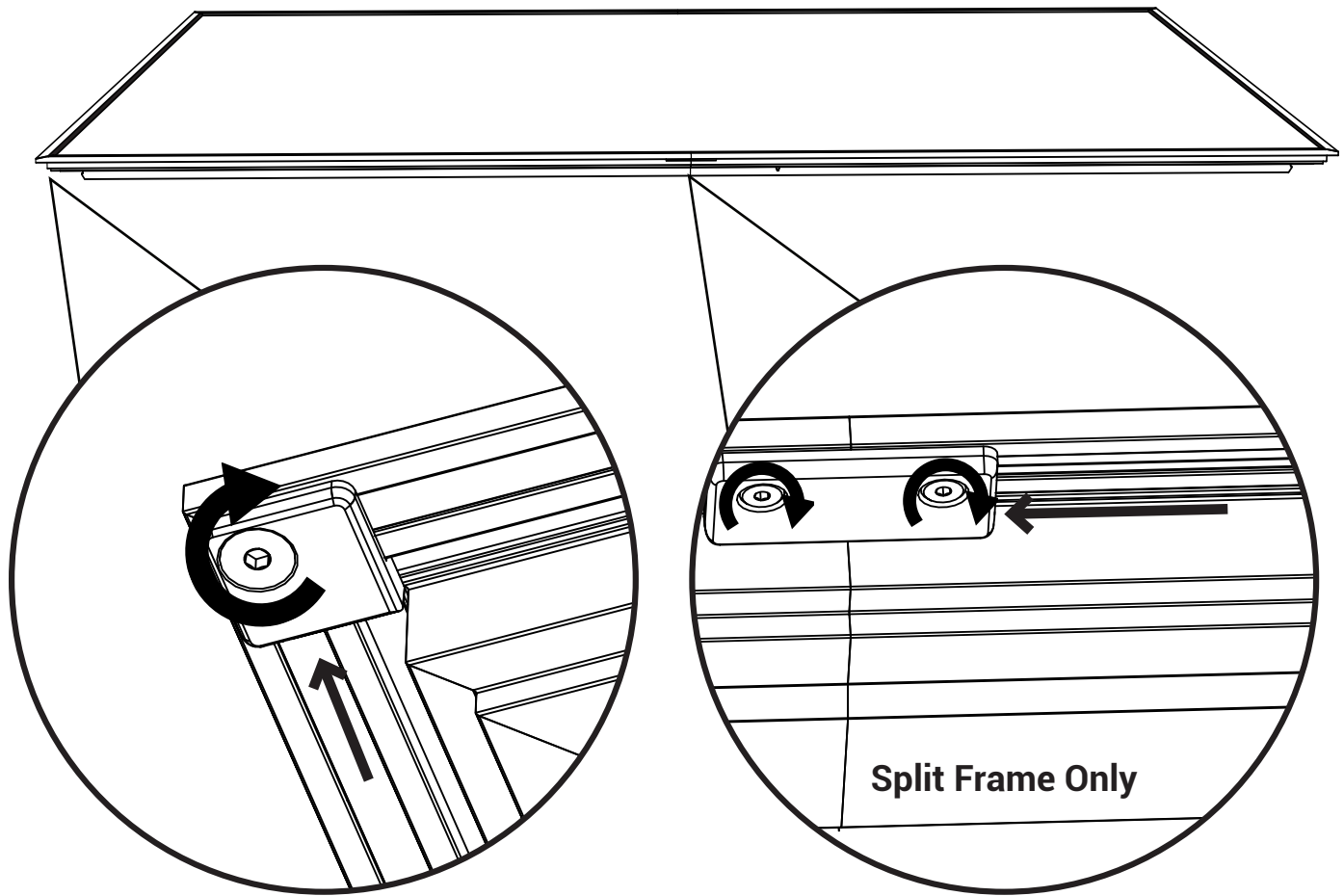

Loosen the screw on the corner plate, slide over to the corner, and hold the corners together while tightening the screw to secure the well aligned corners.

Split Frame Only: Loosen the screw on the center cover plate, slide over to the middle, and hold together trim pieces while tightening the screw to secure the well aligned center trim seam.

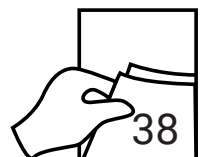

1

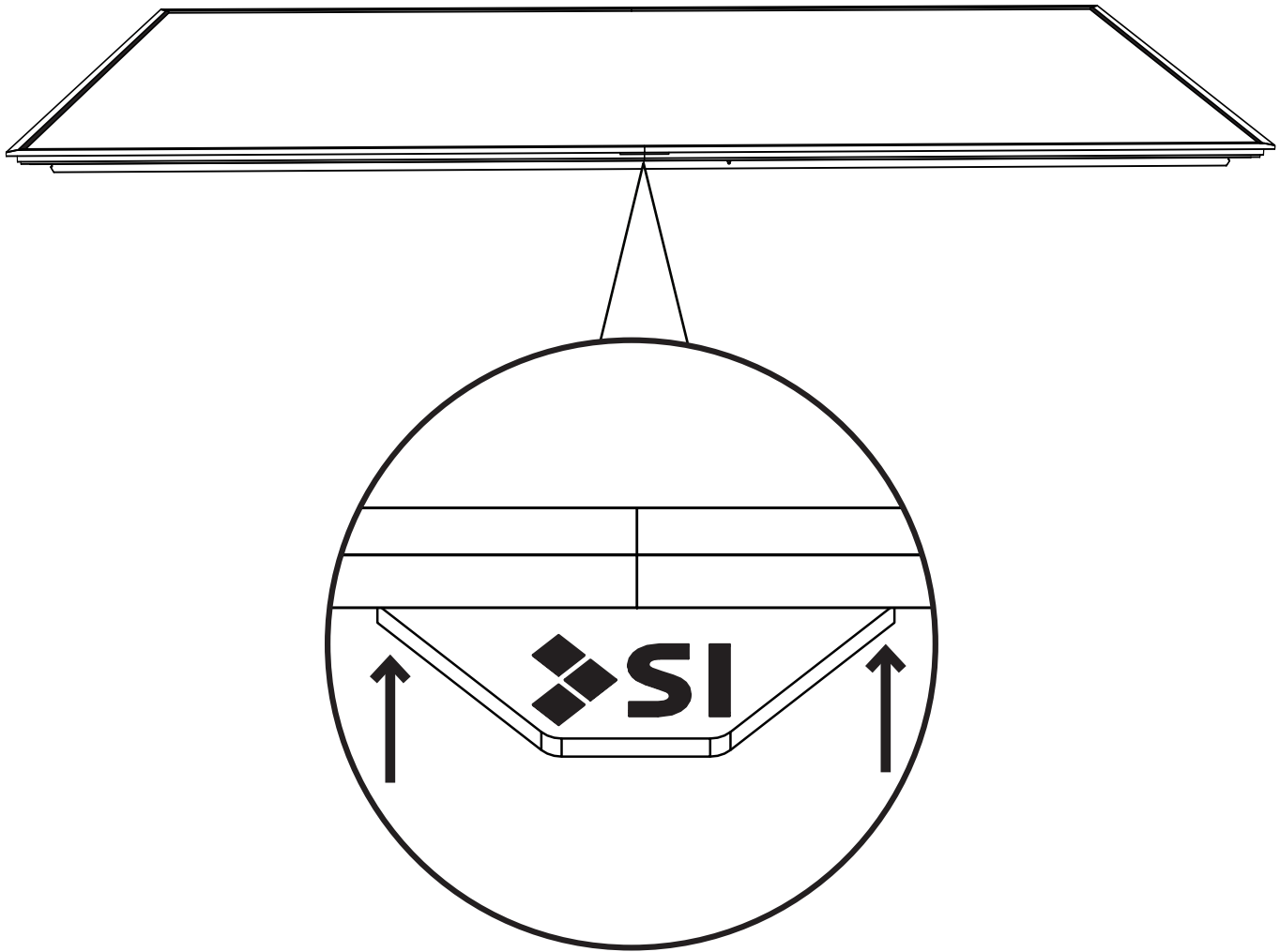

Attach the logo to the trim by holding it at the middle of the horizontal trim and letting the magnet pull it to and attach to the back of the trim.

NOTE: You can also attach the logo to the screen after it is installed on the wall or flown. The trim can attach to either horizontal trim piece. However if your screen has lights make sure the trim is attached to the side of the screen with the lighting harness.



1

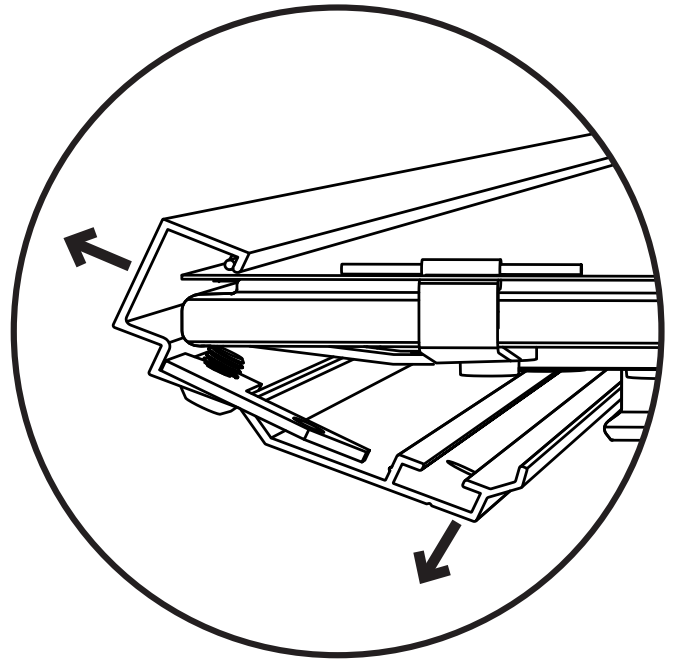
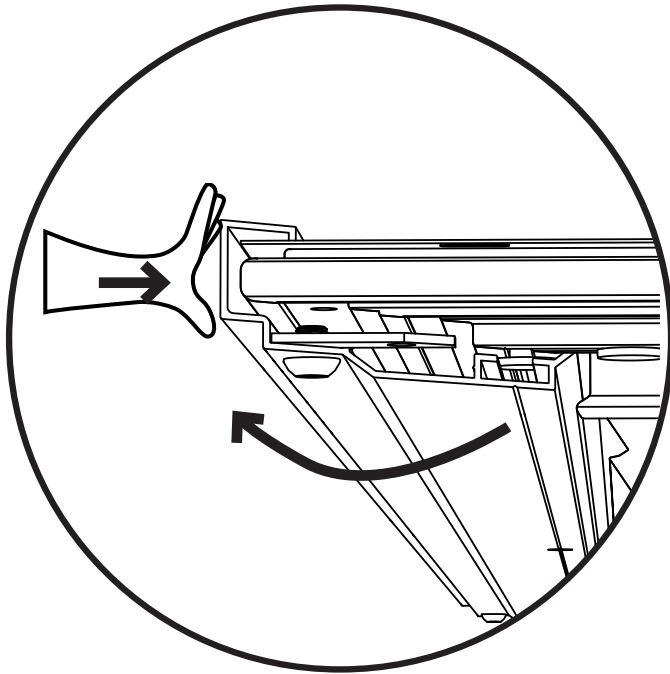

Disconnect the trim at the corners by either removing the screw or loosening the corner plate and sliding over. Then push in on trim pieces while rotating trim off of frame. The magnet will hold the trim in place at first. Therefore you may need to shake the trim at first to get it to rotate away from the frame.

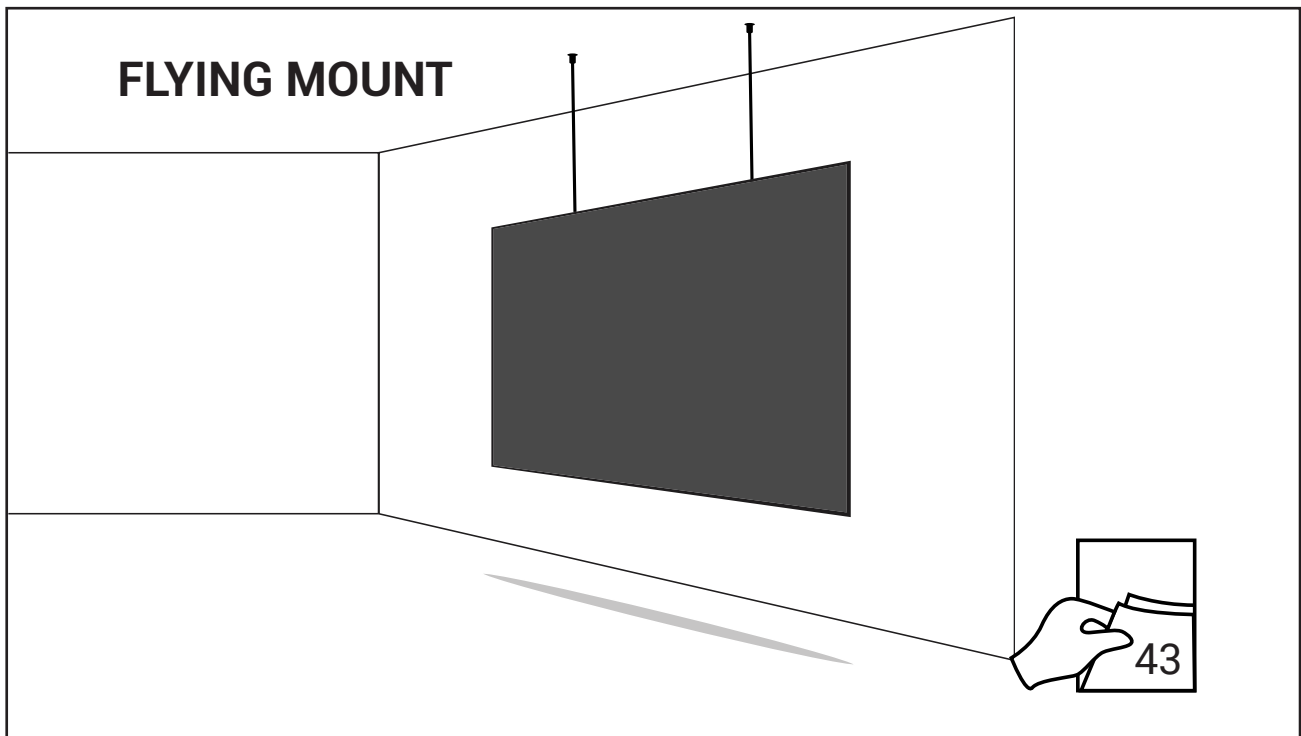
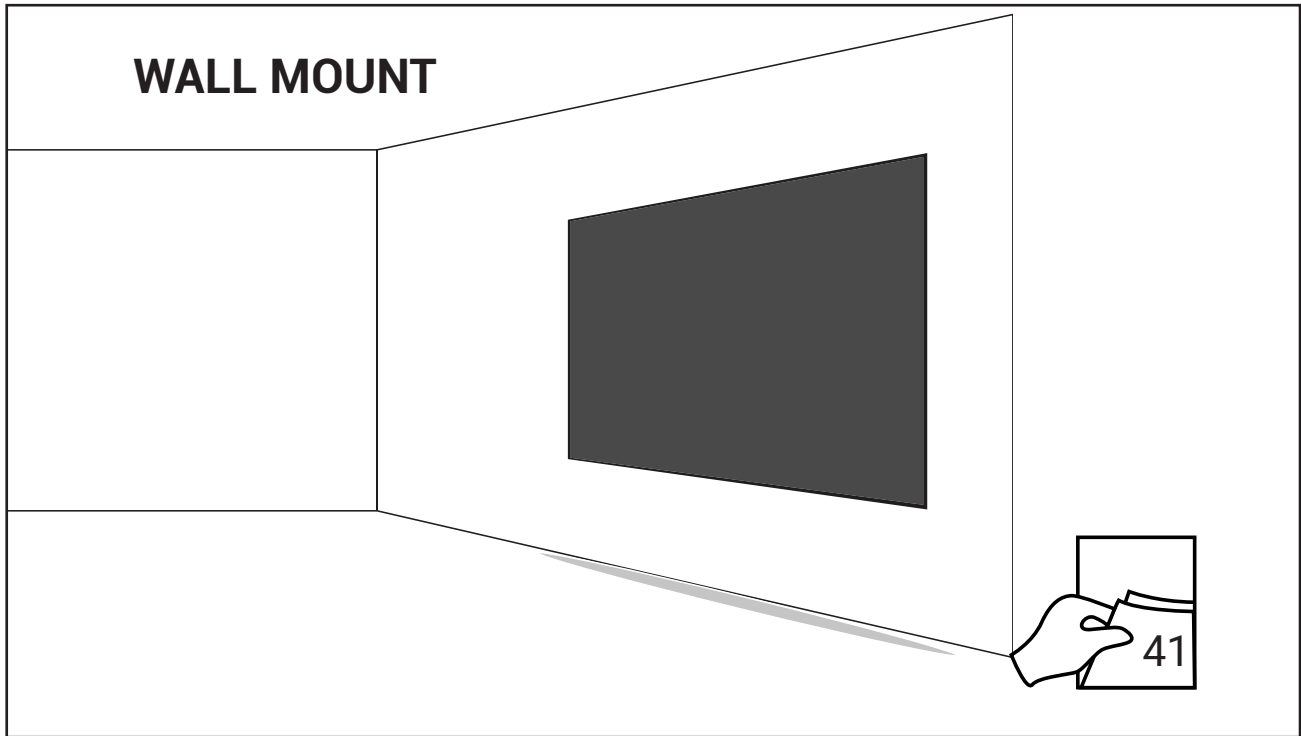



# WALL INSTALLATION

1

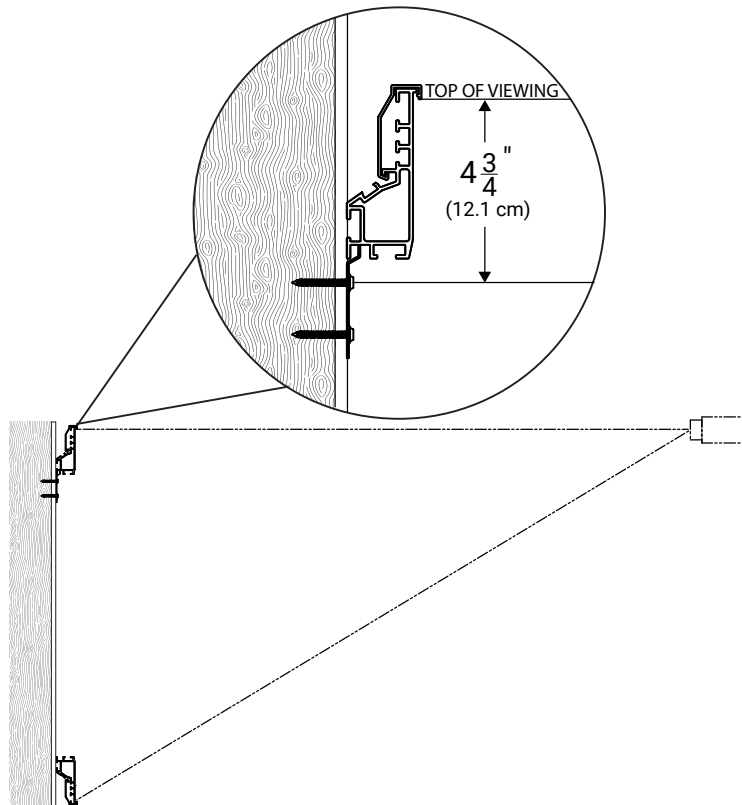
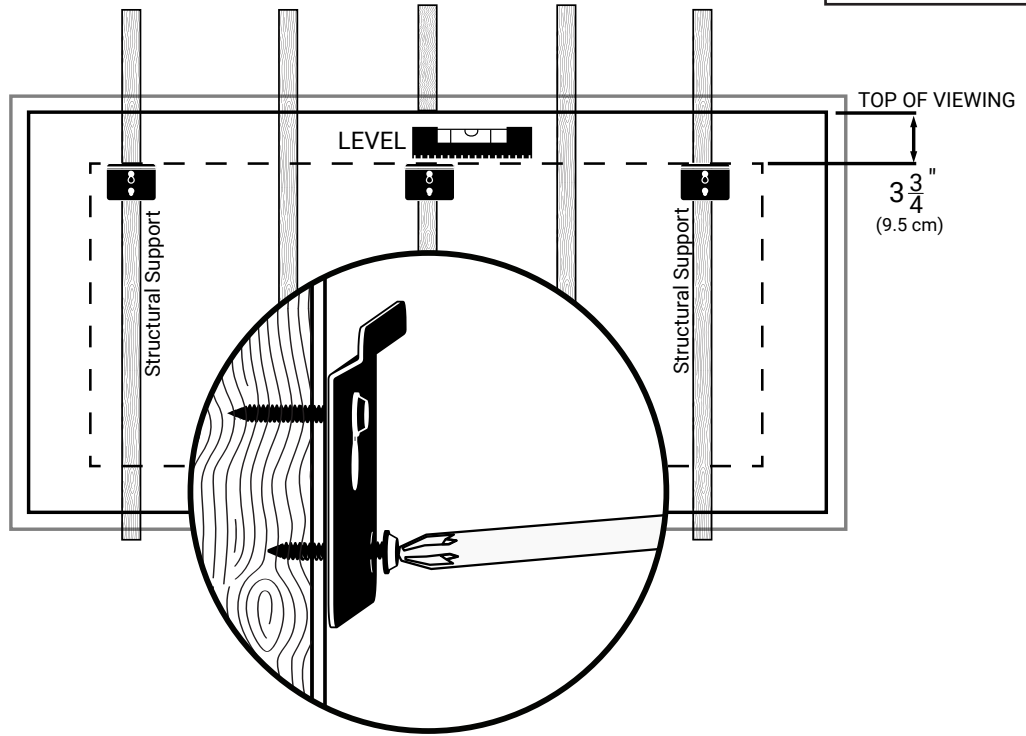
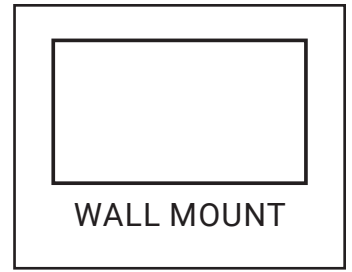

2

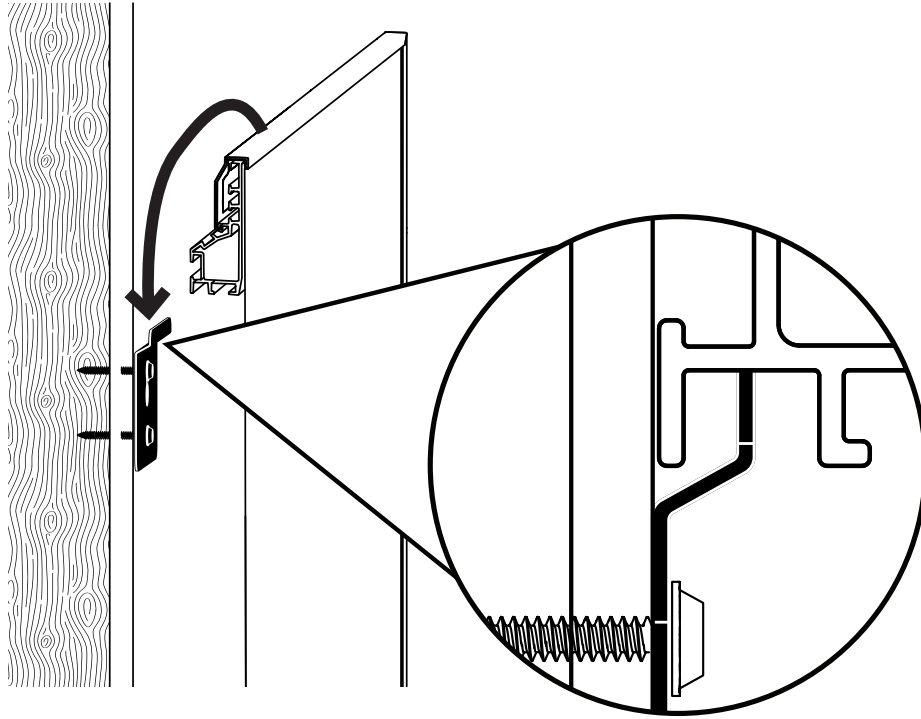
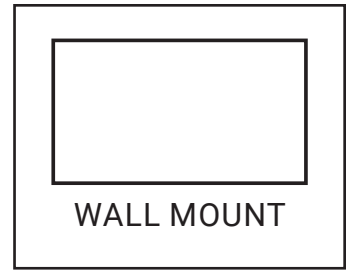

3

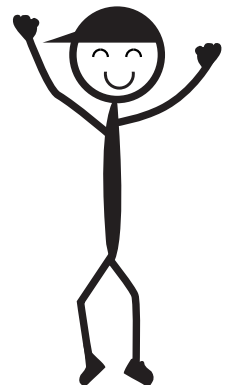
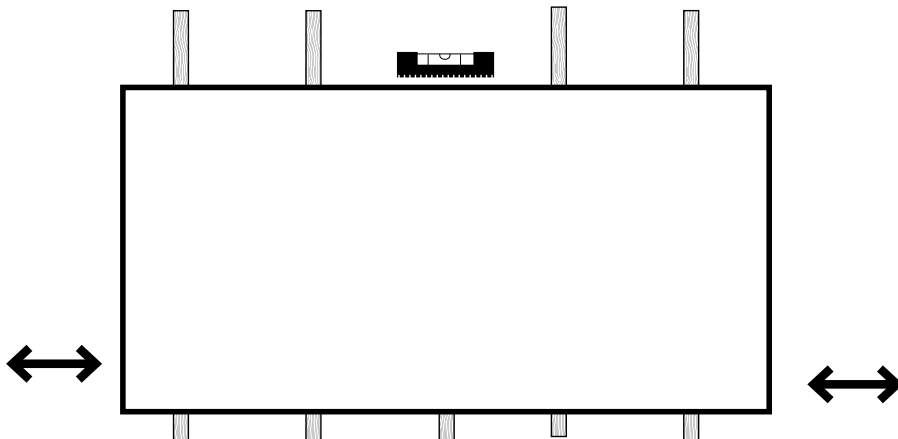

# FLOWN INSTALLATION

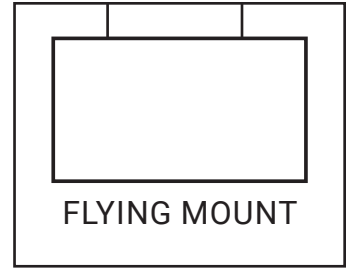

1

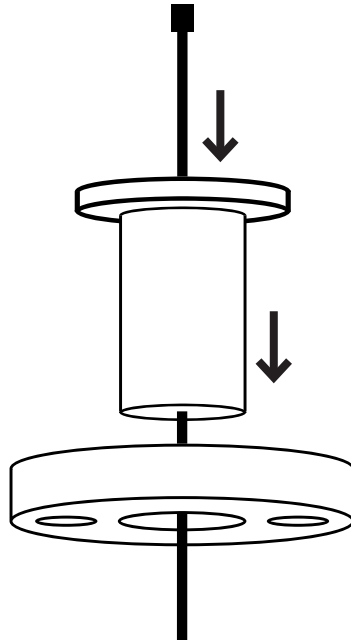

2

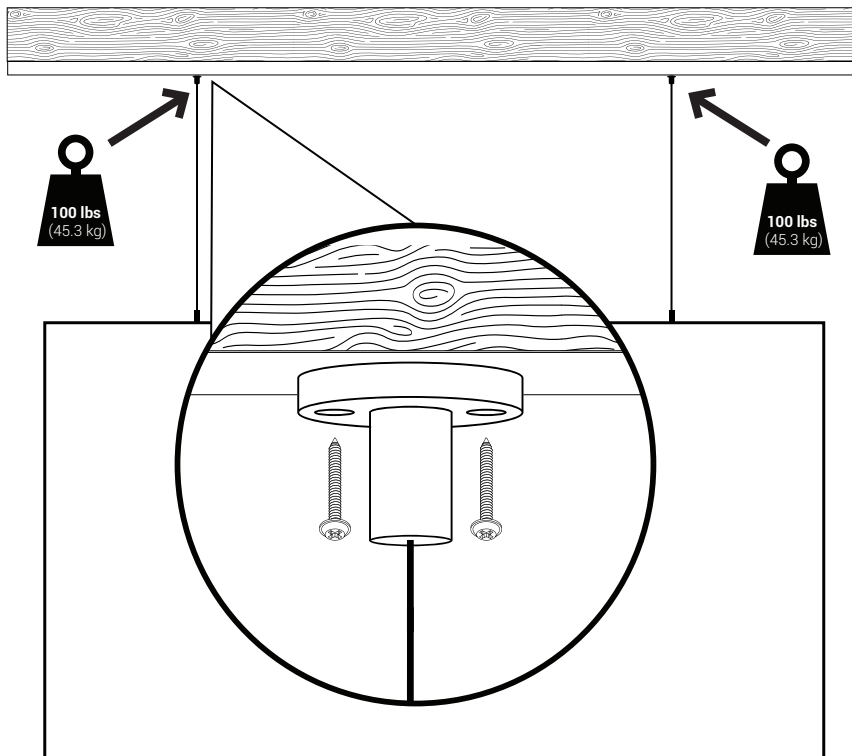

3

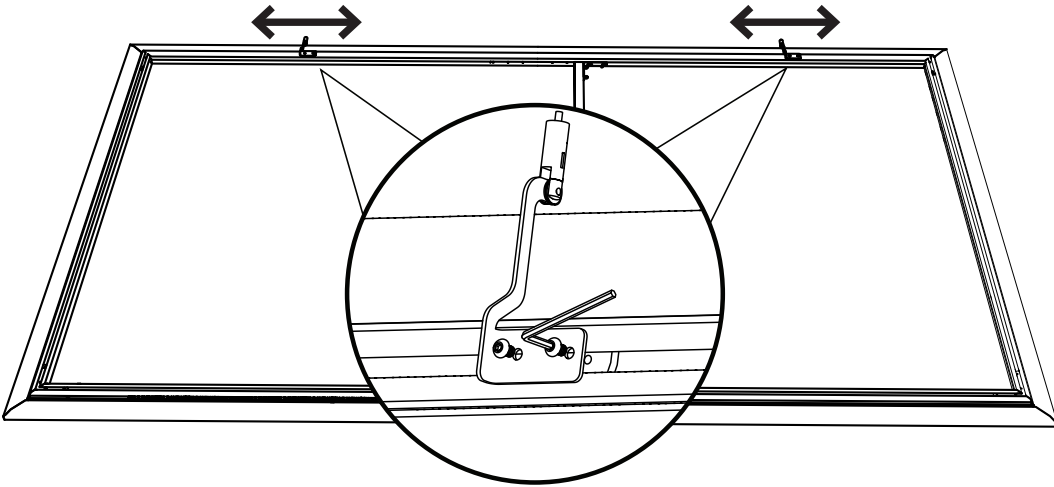
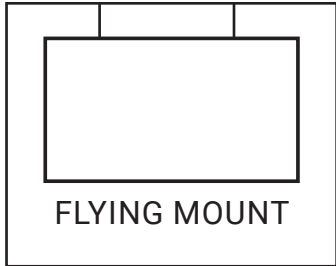

4

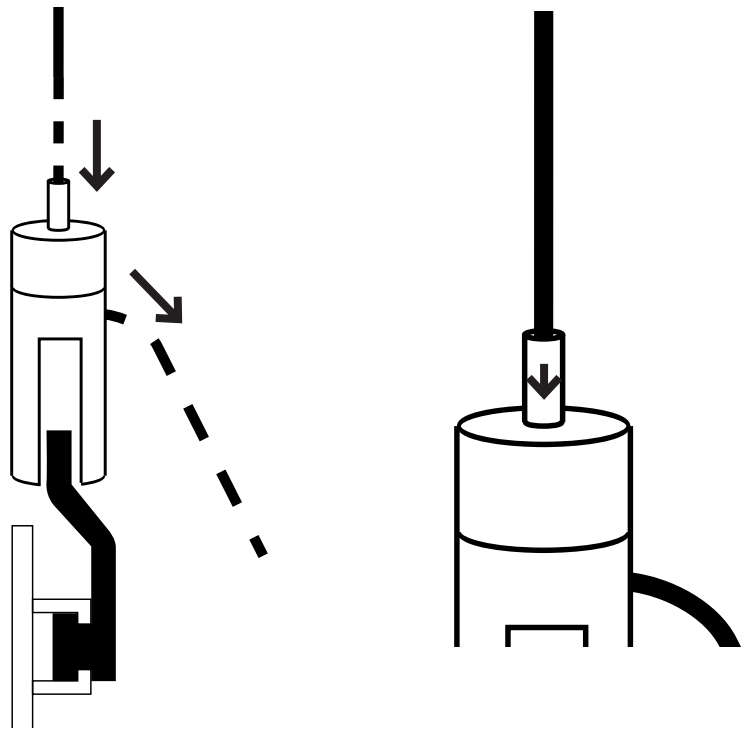

NOTE: If you pull too far the screen can be lowered by pushing down the button on the top of the flying mount.

 We recommend you don't cut the extra cables for future adjustability. Simply tape the extra cable to the back of the screen frame.

IR Controlled Option Only

2013 5CA3	2013 5DA2	2013 41BE	2013 40BF
2013 58A7	2013 59A6	2013 45BA	2013 44BB
2013 54AB	2013 55AA	2013 49B6	2013 48B7
2013 50AF	2013 51AE	2013 4DB2	2013 4CB3
2013 1CE3	2013 1DE2	2013 1EE1	2013 1FE0
2013 18E7	2013 19E6	2013 1AE5	2013 1BE4
2013 14EB	2013 15EA	2013 16E9	2013 17E8
2013 10EF	2013 11EE	2013 12ED	2013 13EC
2013 0CF3	2013 0DF2	2013 0EF1	2013 0FF0
2013 08F7	2013 09F6	2013 0AF5	2013 0BF4
2013 04FB	2013 05FA	2013 06F9	2013 07F8

Backlight IP Option Only

Before attempting to connect your LED IP to Phillips Hue, ensure that the Hue Bridge is powered on and connected to the local WIFI network.

1. Begin by connecting the power supply to an electrical outlet. After a few seconds, the LEDs should power on to a white color.
2. Open the Phillips Hue app on your smart device, and navigate to **Light Setup** in the **settings tab**.
3. Press the **Plus** button in the lower right-hand corner, then press **Search**.
4. It can take several seconds to connect. Once connected, the LEDs will light green.
5. The LED IP will appear in the Phillips Hue app as **Extended Color light 1** and **Dimmable light 1**. Only use **Extended Color Light 1** to control the LED's. **Dimmable Light 1** should be deleted.
6. After the LED IP is connected, it can be renamed and used like any Hue lamp.

Reset Instructions (Required to connect to a different Phillips Hue)

1. Begin with the LED IP powered on
2. Turn off for a minimum of 2 seconds
3. Turn on and wait for LEDs to light
4. Repeat the off/on procedure a total of four times
5. At this point the LEDs will begin blinking for 10 seconds.
6. Once the LEDs stop blinking, repeat the off/on procedure two more times
7. At this point the LED IP will reset. Once complete, the LEDs will light a white color

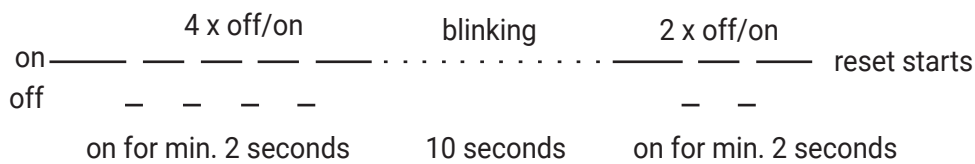

Note: The LED IP can be connected and controlled by only one Phillips Hue Bridge at a time



NOTES:

**9715-B Burnet Road Suite 400, Austin, TX 78758**

Tel: 512-832-6939 Fax: 512-832-6136

[www.screeninnovations.com](http://www.screeninnovations.com)



NOTES:

**9715-B Burnet Road Suite 400, Austin, TX 78758**

Tel: 512-832-6939 Fax: 512-832-6136

[www.screeninnovations.com](http://www.screeninnovations.com)